



Installation Instructions & Owner's Manual

I & INT Series



**12630 US Highway 33 N.
Churubusco, IN 46723**

Phone: (260) 693-1972 Fax: (260)693-0602

TABLE OF CONTENTS:

Preinstallation Instructions for Dealers	Page 3
Bypass Valve	Page 3-4
Installation	Page 5-6
Programming Procedures for Water Softeners	Page 7-8
Operating Displays for Softeners	Page 9
Start-up Instructions	Page 10
Troubleshooting Guide	Page 11-12
Component List	Page 13
Replacement Parts	Page 14-15
Installation Fitting Assemblies	Page 16-17
Specifications	Page 18-19
Quick Reference Guide	Page 20
Ten Year Limited Warranty	Page 21

PREINSTALLATION INSTRUCTIONS FOR DEALERS:

The manufacturer has set the water treatment unit's sequence of cycles, cycle times, salt dose, exchange capacity and gallon capacity. The salt dose refill time has been preset.

The dealer should read this page and guide the installer regarding hardness, day override, and time of regeneration, before installation:

For the installer, the following must be used:

- Set Installer Settings ... Hardness (preset to 20 gpg), Day Override (preset to 14 days), and Time of Regeneration (preset to 2 am).
- Read Normal Operating Displays
- Set Time of Day
- Read Power Loss & Error Display

Water Softeners:

During operation, the normal user displays are time of day, gallons per minute or gallons remaining before regeneration will occur. Days remaining is an optional display but is not normally used on metered softeners. Each of these can be viewed by pressing NEXT to scroll through them. When stepping through any displays or programming, if no buttons are pressed within 5 minutes, the display returns to a normal user display. Any changes made prior to the 5 minute time out are incorporated. To quickly exit any Programming, Installer Settings, etc., press SET CLOCK. Any changes made prior to the exit are incorporated.

If desired, two regenerations within 24 hours are possible with a return to the preset program. To do a *double regeneration*:

1. Press the REGEN button ONCE. REGEN TODAY will flash on the display.
2. Press and hold the REGEN button for three seconds until a regeneration begins.

Once the valve has completed the immediate regeneration, the valve will regenerate one more time at the preset time.

BYPASS VALVE:

The bypass valve is typically used to isolate the control valve from the plumbing system's water pressure in order to perform control valve repairs or maintenance. The 1" full flow bypass valve incorporates four positions including a diagnostic position that allows a service technician to have pressure to test a system while providing untreated bypass water to the building.

Be sure to install bypass valve onto main control valve, before beginning plumbing or make provisions in the plumbing system for a bypass.

The bypass body and rotors are glass filled Noryl[®] and the nuts and caps are glass filled polypropylene. All seals are self-lubricating EPDM to help prevent valve seizing after long periods of non-use. Internal "O" Rings can easily be replaced if service is required.

The bypass consists of two interchangeable plug valves that are operated independently by red arrow shaped handles. The handles identify the direction of flow. The plug valves enable the bypass valve to operate in four positions.

1. **Normal Operation Position:** The inlet and outlet handles point in the direction of flow indicated by the engraved arrows on the control valve. Water flows through the control valve for normal operation of a water softener or filter. During the regeneration cycle this position provides regeneration water to the unit, while also providing untreated water to the distribution system (**Fig. 1**).
2. **Bypass Position:** The inlet and outlet handles point to the center of the bypass. The system is isolated from the water pressure in the plumbing system. Untreated water is supplied to the building (**Fig. 2**).
3. **Diagnostic Position:** The inlet handle points toward the control valve and the outlet handle points to the center of bypass valve. Untreated supply water is allowed to flow to the system and to the building, while not allowing water to exit from the system to the building (**Fig. 3**). This allows the service technician to draw brine and perform other tests without the test water going to the building.
NOTE: The system must be rinsed before returning the bypass valve to the normal position.
4. **Shut Off Position:** The inlet handle points to the center of the bypass valve and the outlet handle points away from the control valve. The water is shut off to the building. The water treatment system will depressurize upon opening a tap in the building. A negative pressure in the building combined with the softener being in regeneration could cause a siphoning of brine into the building. If water is available on the outlet side of the softener it is an indication of water bypassing the system (**Fig. 4**) (i.e. a plumbing cross-connection somewhere in the building).

NORMAL OPERATION POSITION

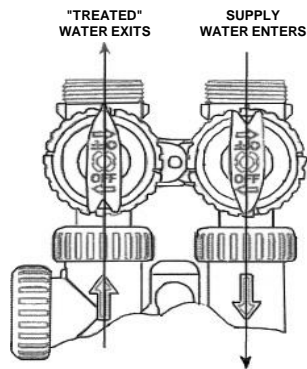

Figure 1

BYPASS POSITION

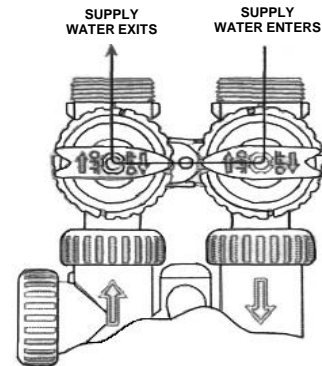

Figure 2

DIAGNOSTIC POSITION

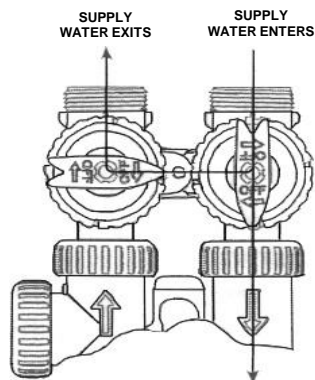

Figure 3

SHUT OFF POSITION

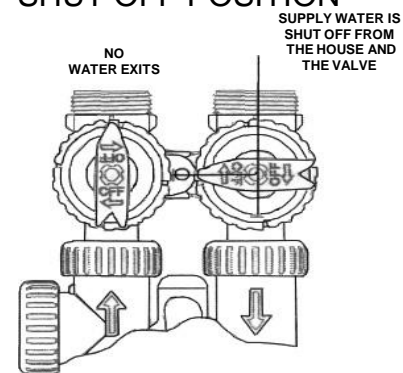

Figure 4

INSTALLATION:

GENERAL INSTALLATION & SERVICE WARNINGS

The control valve, fittings and/or bypass are designed to accommodate minor plumbing misalignments. There is a small amount of "give" to properly connect the piping but the water softener is not designed to support the weight of plumbing.

Do not use Vaseline, oils, other hydrocarbon lubricants or spray silicone anywhere. A silicone lubricant may be used on black "O" Rings, but is not necessary. *Avoid any type of lubricants, including silicone, on red or clear lip seals.*

Do not use pipe dope or other sealants on threads. Teflon[®] tape must be used on the threads of the 1" NPT inlet and outlet and on the threads for the drain line connection. Teflon[®] tape is not used on the nut connections or caps because "O" Ring seals are used. The nuts and caps are designed to be unscrewed or tightened by hand or with the special plastic Service Wrench, #CV3193. If necessary pliers can be used to unscrew the nut or cap. Do not use a pipe wrench to tighten nuts or caps. *Do not place screwdriver in slots on caps and/or tap with a hammer.*

SITE REQUIREMENTS

- water pressure -- 25-100 psi
- water temperature -- 33-100°F (0.5-37.7°C)
- electrical -- 115/120 V, 60 Hz uninterrupted outlet
- the tank should be on a firm level surface
- current draw is 0.5 amperes
- the plug-in transformer is for dry locations only

WELL WATER INSTALLATION

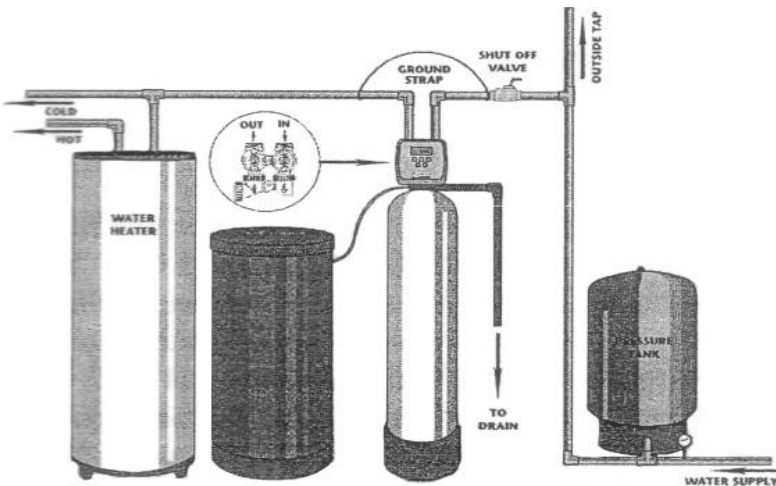

MUNICIPAL INSTALLATION

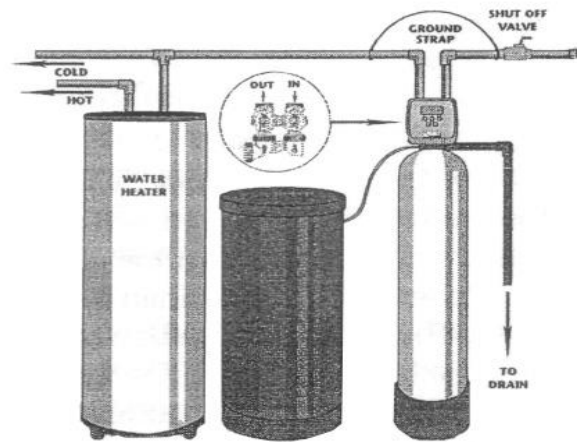

1. The distance between the drain and the water conditioner should be as short as possible.
2. Since salt must be periodically added to the brine tank, it should be located where it is easily accessible.
3. Do not install any water conditioner with less than 10 feet of piping between its outlet and the inlet of a water heater.
4. Do not locate unit where it or its connections (including the drain and overflow lines) will ever be subjected to room temperatures under 34°F.

6. **INLET/OUTLET PLUMBING:** Be sure to install Bypass Valve onto main control valve before beginning plumbing. Make provisions to bypass outside hydrant and cold hard water lines at this time. Install an inlet shutoff valve and plumb to the unit's bypass valve inlet located at the right rear as you face the unit. There are a variety of installation fittings available. They are listed under Installation Fitting Assemblies, pages 16-17. When assembling the installation fitting package (inlet and outlet), connect the fitting to the plumbing system first and then attach the nut, split ring, and "O" Ring. Heat from soldering or solvent cements may damage the nut, split ring, or "O" Ring. Solder joints should be cool and solvent cements should be set before installing the nut, split ring, and "O" Ring. Avoid getting solder flux, primer, and solvent cement on any part of the "O" Rings, split rings, bypass valve, or control valve. If the building's electrical system is grounded to the plumbing, install a copper grounding strap from the inlet to the outlet pipe. Plumbing must be done in accordance with all applicable local codes.

7. **DRAIN LINE:** First, be sure that the drain can handle the backwash rate of the system. Solder joints near the drain must be done prior to connecting the drain line flow control fitting. Leave at least 6" between the drain line flow control fitting and solder joints. Failure to do this could cause interior damage to the flow control. Install a 1/2" I.D. flexible plastic tube to the Drain Line Assembly or discard the barbed fitting and use 3/4" NPT fitting of rigid pipe (recommended). If the backwash rate is greater than 7 gpm, use a 3/4" drain line. Where the drain line is elevated but empties into a drain below the level of the control valve, form a 7" loop at the discharge end of the line so that the bottom of the loop is level with the drain connection on the control valve. This will provide an adequate anti-siphon trap. Piping the drain line <10 ft is normally not a problem. Be sure adequate pressure is available (40-60 psi is recommended). Where the drain empties into an overhead sewer line, a sink-type trap must be used. Run drain tube to its discharge point in accordance with plumbing codes. Pay special attention to codes for air gaps and anti-siphon devices.

8. **BRINE TANK CONNECTION:** Install the 3/8" O.D. polyethylene tube from the Refill Elbow to the Brine Valve in the brine tank.

9. **OVERFLOW LINE CONNECTION:** *An overflow drain line is recommended where a brine overflow could damage furnishings or the building structure.* Your softener is equipped with a brine tank safety float which greatly reduces the chance of an accidental brine overflow. In the event of a malfunction, however, an *overflow line connection* will direct the "overflow" to the drain instead of spilling on the floor where it could cause considerable damage. This fitting is an elbow on the side of the brine tank. Attach a length of 1/2" I.D. tubing to fitting and run to drain. Do not elevate overflow line higher than 3" below bottom of overflow fitting. Do not "tie" this tube into the drain line of the control valve. Overflow line must be a direct, separate line from overflow fitting to drain, sewer, or tub. Allow an air gap as per the drain line instructions.



CAUTION: Never insert a drain line into a drain, sewer line, or trap. Always allow an air gap between the drain line and the wastewater to prevent the possibility of sewage being back-siphoned into the conditioner.

PROGRAMMING PROCEDURES FOR WATER SOFTENERS:

1. Set time of day:

Time of day should only need to be set after extended power outages or when daylight saving time begins or ends. If an extended power outage occurs, the time of day will flash on and off indicating that the time should be reset.

STEP 1 -- Press SET CLOCK.

STEP 2 -- Current Time (hour): Set the hour of the day using ▼ or ▲ buttons. AM/PM toggles after 12. Press NEXT to go to step 3.

STEP 3 -- Current Time (minutes): Set the minutes using ▼ or ▲ buttons. If it is desired to go back up to the previous step press REGEN button once. Pressing NEXT will exit Set Clock and return to the general operating display (page 9).

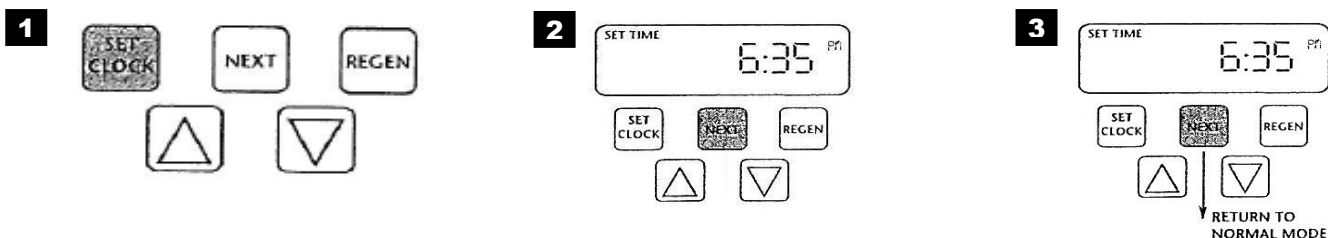

2. Programming:

NOTE: The manufacturer has preset the unit so that the gallons between regenerations will be automatically calculated after the hardness is entered.

STEP 1 -- Press NEXT and ▲ simultaneously for 3 seconds.

STEP 2 -- *Hardness:* Set the amount of hardness in grains per gallon (default 20) using the ▼ or ▲ buttons. The allowable range is from 1 to 150 in 1 grain increments.
Note: Increase the grains per gallon if soluble iron is present (1 ppm = 3 gpg).

Press NEXT to go to step 3. Press REGEN if you want to exit.

STEP 3 -- *Day Override:* The manufacturer has factory set this at 14 days as the default. This is the maximum number of days between regenerations. If this is set to "OFF" regeneration initiation is based solely on gallons used. If any number is set (allowable range from 1 to 28), a regeneration initiation will be called for on that day even if a sufficient number of gallons were not used to call for a regeneration. Set Day Override using ▼ or ▲ buttons (14 is recommended):

- set number of days between regeneration (1 to 28); or
- set to "OFF"

Press NEXT to go to step 4. Press REGEN if you need to return to the previous step.

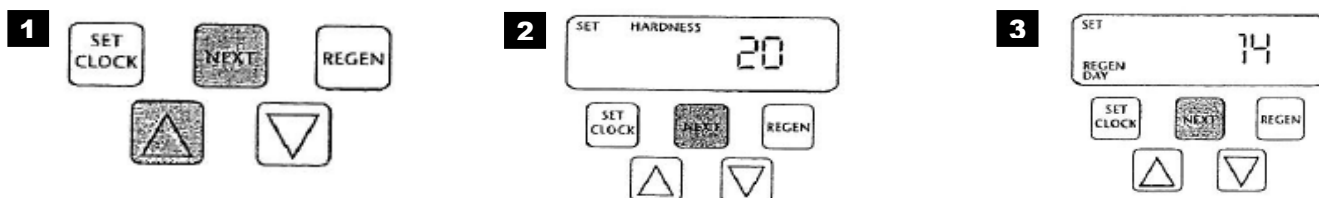

2. Programming cont'd:

STEP 4 -- Regeneration Hour: The manufacturer has factory set 2:00 a.m. as the default. This is the hour of day for regeneration and can be reset by using ▼ or ▲ buttons. "AM/PM" toggles after 12. The default time is 2:00 a.m. (recommended for a normal household). Press NEXT to go to step 5. Press REGEN if you need to return to the previous step.

STEP 5 -- Regeneration Minutes: Set the minutes using ▼ or ▲ buttons. Press NEXT to exit Installer Settings. Press REGEN if you need to return to the previous step. To initiate a manual regeneration immediately, press and hold the REGEN button for three seconds. The system will begin to regenerate immediately. The control may be manually stepped through the regeneration cycles by pressing REGEN.

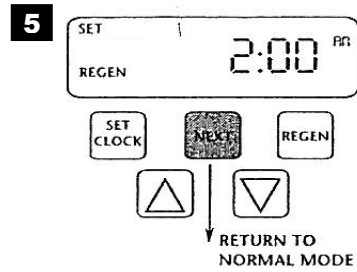
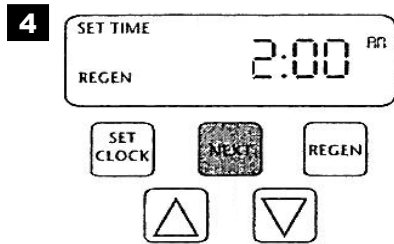

OPERATING DISPLAYS FOR WATER SOFTENERS:

1. **General Operation:** When the system is operating, one of the three displays may be shown. Pressing NEXT will alternate between displays. One of the displays is always the current time of day. The second display shows the current treated water flow rate through the system in Gallons Per Minute. The third display shows the current volume remaining in Gallons. Capacity remaining is the gallons that will be treated before the system goes through a regeneration cycle.

The user can scroll between the displays as desired.

If the system has called for a regeneration that will occur at the preset time of regeneration, the words REGEN TODAY will appear on the display.

If a water meter is installed, the word "Softening" flashes on the display when water is being treated (i.e. water is flowing through the system).

2. **Regeneration Mode:** Typically a system is set to regenerate at a time of no water use. If there is a demand for water when the system is regenerating, untreated water will be delivered. When the system begins to regenerate, the display will change to include information about the step of the regeneration process and the time remaining for that step to be completed. The system runs through the steps automatically and will reset itself to provide treated water when the regeneration has been completed.

3. **Manual Regeneration:** Sometimes there is a need to regenerate before the control valve calls for it. This may be needed if a period of heavy water use is anticipated or when the system has been operated without salt.

- To initiate a manual regeneration at the preset delayed regeneration time, press and release REGEN. The words "REGEN TODAY" will flash on the display to indicate that the system will regenerate at the preset delayed regeneration time.
- If you pressed the REGEN button in error, pressing the button again will cancel the command.
- To initiate a manual regeneration immediately, press and hold the REGEN button for three seconds. The system will begin to regenerate immediately. This command cannot be cancelled.

4. **Power Loss:** If the power goes out for less than two hours, the system will automatically reset itself. If an extended power outage occurs, the time of day will flash on and off which indicated the time of day should be reset. *The system will remember all other settings.*

Error Message: If the word "ERROR" and a number are alternately flashing on the display record the number and contact the dealer for help. This indicates that the control valve was not able to function properly.

GENERAL OPERATION DISPLAYS

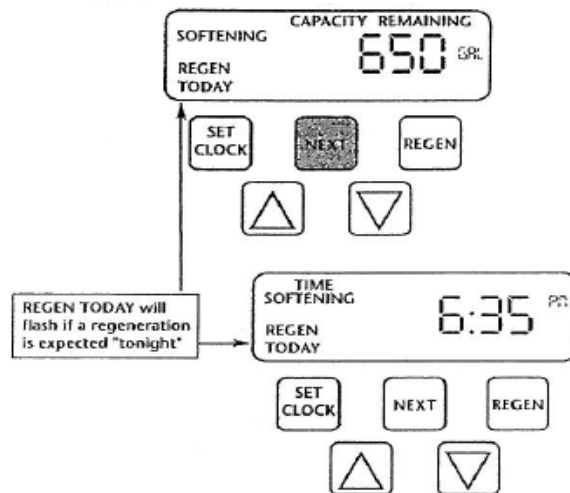

REGENERATION MODE



MANUAL REGENERATION

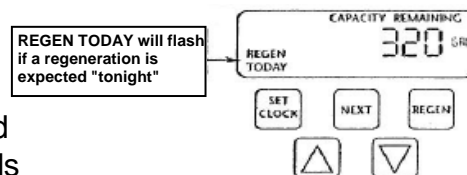

POWER LOSS OR ERROR

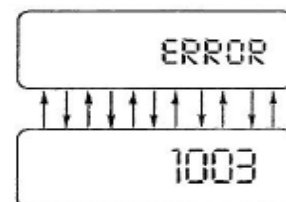

START-UP INSTRUCTIONS FOR WATER SOFTENERS:

- After installation is complete, rotate bypass handles to bypass mode (*see Fig. 2 on page 4*).
- Turn on water and check for leaks.
- Fully open a cold water faucet -- preferably a laundry sink or bathtub with no aerator.
- Allow water to run until clear to rid pipes of debris which may have occurred during installation.

System regeneration sequence is in the following order. (If it is desired to change this sequence, please refer to the Dealer Manual or contact the manufacturer.)

- 1) **BRINE TANK REFILL**
- 2) **1.5 HOURS (90 minutes) OF SOFTENING MODE WHILE SALT IS DISSOLVING**
- 3) **BACKWASH**
- 4) **BRINE DRAW AND SLOW RINSE**
- 5) **FAST RINSE**
- 6) **END (return to service)**

The system is now ready for filling with water and for testing.

1. With the softener in the bypass mode (*Fig. 2 on page 4*) and the control valve in normal operation where the display shows either the time of day, flow rate of treated water or the gallons remaining: Manually add 5" of water to the brine tank.
NOTE: If too much water is put into the brine tank during softener start up it could result in a "salty water" complaint after the first regeneration.
During the first regeneration the unit will draw out the initial volume of brine/regenerant and refill it with the correct preset amount.
2. Press and hold the **REGEN** button until the motor starts. Release button. The display reads "FILL" and the remaining time in this step is counting down. Check to verify that the brine tank is filling at a rate of 1/2 gallon per minute. Since the brine tank was already filled in Step 1 press **REGEN** again and the display will read SOFTENING 90 (During a full regeneration this will be a 1.5 hour period for salt to dissolve). Press **REGEN** again to put the valve into "BACKWASH." Unplug the transformer so that the valve will not cycle to the next position. Open the inlet handle of the bypass valve very slightly allowing water to fill the tank slowly in order to expel air.
 **CAUTION: If water flows too rapidly there will be loss of media to the drain.**
3. When the water is flowing steadily to the drain without the presence of air, slowly open the inlet valve. Restore power and momentarily press the **REGEN** button to advance the control to the "BRINE" position.
4. The bypass is now in the diagnostic mode (*Fig. 3 on page 4*). Check to verify that water is being drawn from brine tank with no leaks or bubbles in the brine line. There should be a slow flow to the drain.
5. Momentarily press **REGEN** again until the display reads "RINSE." There should be a rapid flow to the drain. Unplug transformer to keep the valve in the "RINSE" position. Allow to run until steady, clear and without air. While the unit is rinsing load the brine tank with water softener salt. Restore power.
6. Place bypass valve in the normal operating mode (*Fig. 1 on page 4*) by opening the outlet bypass handle. Press **REGEN** and the unit will return to the service position with time of day being displayed.

TROUBLESHOOTING GUIDE - SOFTENERS AND FILTERS:

PROBLEM	CAUSE	CORRECTION
1. Timer does not display time of day	A. transformer unplugged	A. reconnect transformer
	B. no power at outlet	B. repair or use working outlet
	C. defective transformer	C. replace transformer
	D. defective PC board	D. replace PC board
2. Timer does not display correct time of day	A. outlet is on a switch	A. use unswitched outlet
	B. power outage	B. reset time of day
	C. defective PC board	C. replace PC board
3. No softening display when water is flowing	A. bypass valve in bypass position	A. put bypass in service position
	B. meter cable disconnected	B. reconnect PC board
	C. restricted/stalled meter turbine	C. remove meter and check for debris
	D. defective meter	D. replace meter
	E. defective PC board	E. replace PC board
4. Unit regenerates at wrong time of day	A. past power outage	A. reset time of day
	B. incorrect time of day displayed	B. reset time of day
	C. time of regenerant set incorrectly	C. reset time of regeneration
	D. control set at "on 0"	D. check with regeneration time option in programming
	E. control set at "NORMAL + on 0"	E. check with regeneration time option in programming
5. "Error" followed by code # <ul style="list-style-type: none"> • "Error" code 1001- unable to recognize start of regeneration • "Error" code 1002- unexpected stall • "Error" code 1003- motor ran too long • Timed out trying to reach next cycle position • If other codes appear contact factory 	A. valve has just been serviced	A. press NEXT and REGEN for 3 secs or momentarily unplug power source from PC board.
	B. foreign material stuck in valve	B. check piston and spacer stack for obstruction
	C. excessive piston resistance	C. replace piston(s) and spacer stack assembly
	D. piston not in home position	D. press NEXT and REGEN or momentarily unplug PC board power
	E. motor gears not fully engaged - motor wires broken - failed motor	E. check motor wiring
	F. center drive gear reflector dirty or damaged - missing or broken gear	F. replace or clean drive gear(s)
	G. drive bracket incorrectly aligned on backplate	G. reset drive bracket
	H. PC board is damaged or defective	H. replace PC board
	I. PC board incorrectly aligned on drive bracket	I. reset PC board onto drive bracket

PROBLEM	CAUSE	CORRECTION
6. Valve stalled in regeneration	A. motor not operating	A. replace motor
	B. no power at outlet	B. repair outlet or use working outlet
	C. defective transformer	C. replace transformer
	D. defective PC board	D. replace PC board
	E. broken drive gear or drive cap assembly	E. replace gear or drive cap assy.
	F. broken piston retainer	F. replace drive cap assy.
	G. broken main or regenerant piston	G. replace main or regenerant piston
7. Valve does not regenerate automatically when REGEN button is depressed	A. transformer unplugged	A. connect transformer and PC board power
	B. no power at outlet	B. restore power
	C. broken drive gear or drive cap assy.	C. replace gear or drive cap assy.
	D. defective PC board	D. replace PC board
8. Valve does not regenerate automatically but does when REGEN button is depressed	A. bypass valve not in normal operating mode	A. see bypass diagrams on page 4
	B. meter disconnected	B. reconnect PC board
	C. obstructed meter turbine	C. clear obstruction
	D. defective meter	D. replace meter
	E. programming error	E. review programming
	F. defective PC board	F. replace PC board
9. Time of day flashes on and off	A. Power has been out more than two hours. Transformer was unplugged from either wall or PC board. NEXT and REGEN were pressed to reset the valve.	A. reset time of day

COMPONENT LIST:

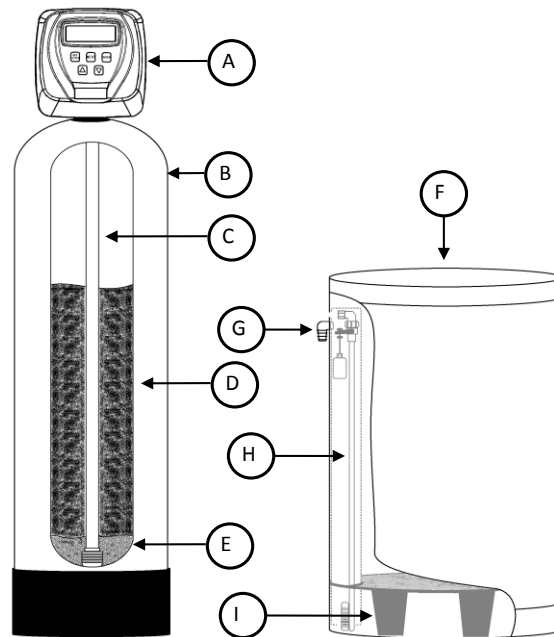

REF#	Description	Unit									
		IC0835	IC1035	I0844	I0948	I1054	I1248	I1365	INT1035	I10948	I11248
A	Control Valve	IC0835VlvAssy	IC1035VlvAssy	I0844VlvAssy	I0948VlvAssy	I1054VlvAssy	I1248VlvAssy	I1365VlvAssy	INT1035VlvAss	I10948VlvAssy	I11248VlvAssy
B	Mineral Tank	MTP1035GR	MTP1035GR	MTP0844GR	MTP0948GR	MTP1054GR	MTP1248GR	MTP1354N	MTP1035N	MTP0948GR	MTP1248GR
C	Distributor	T04-35	T04-35	T04-48	T04-48	T04-54	T04-48	T04-54	D1005-48	D1005-48	D1005-48
D	Resin	H075	H10	H075	H10	H10/H05	H10 (X2)	H10 (X2)/H05	FH10	FH10	FH10 (X2)
E	1/4 x 1/8 gravel	N/A	N/A	N/A	N/A	N/A	N/A	N/A	QC20	QC20	QC25
F	Brine Tank Assy.	BT1134ASSY	BT1134ASSY	BT1833ASSY	BT1833ASSY	BT1833ASSY	BT1833ASSY	BT1833ASSY	BT1134ASSY	BT1833ASSY	BT1833ASSY
G	Overflow fitting	BT-OVERFLO	BT-OVERFLO	BT-OVERFLO	BT-OVERFLO	BT-OVERFLO	BT-OVERFLO	BT-OVERFLO	BT-OVERFLO	BT-OVERFLO	BT-OVERFLO
H	Safety Brine Valve	SBV33ASSY	SBV33ASSY	SBV33ASSY	SBV33ASSY	SBV33ASSY	SBV33ASSY	SBV33ASSY	SBV33ASSY	SBV33ASSY	SBV33ASSY
I	Salt Platform	BTSG11	BTSG11	BTSG18	BTSG18	BTSG18	BTSG18	BTSG18	BTSG11	BTSG18	BTSG18

- Notes:**
1. For complete control valve breakdown see "Replacement Parts" on pages 14-15.
 2. For list of bypass fittings see "Installation Fitting Assemblies" on pages 16-17.
 3. For unit specifications see "Specifications" on pages 18-19.

REPLACEMENT PARTS:

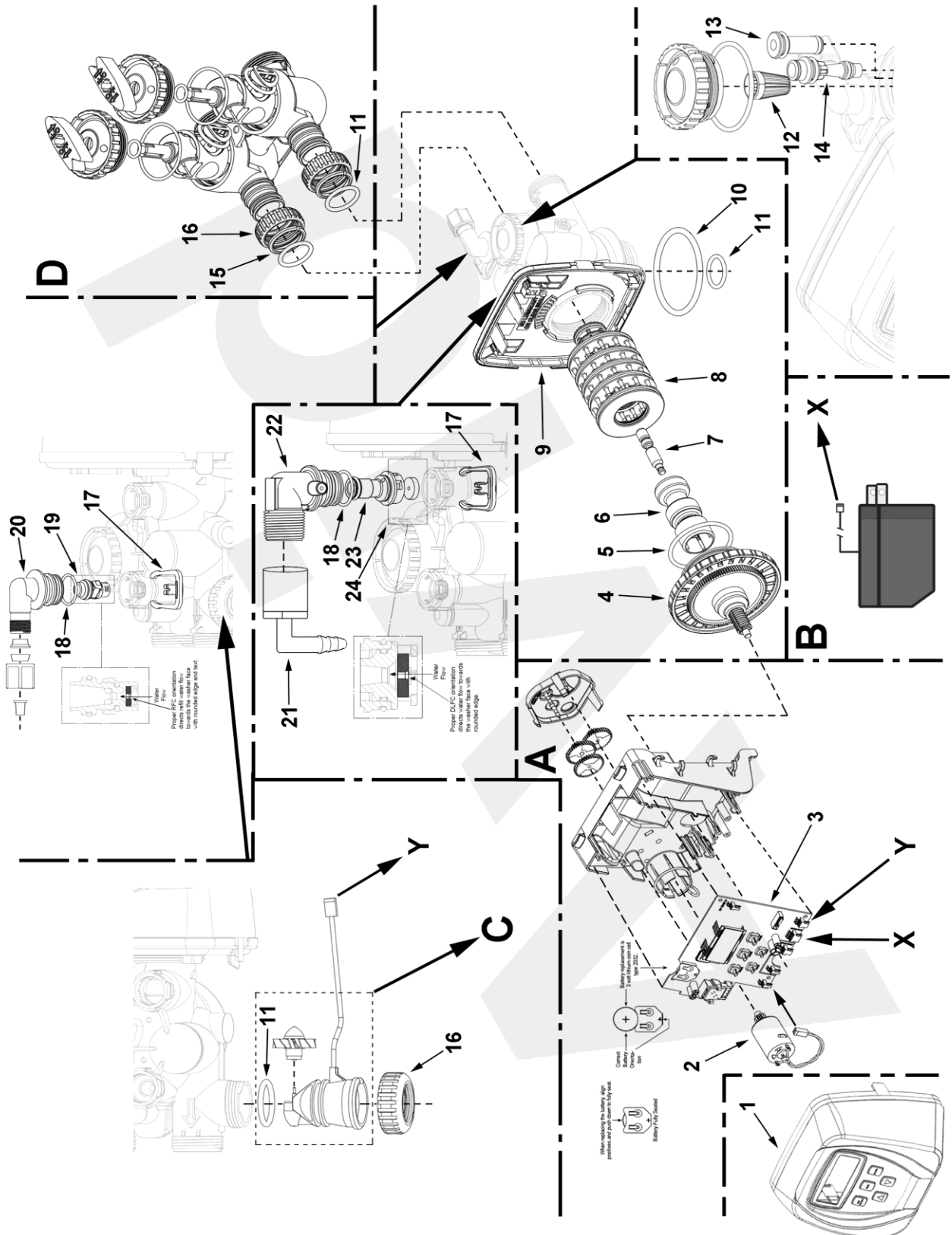

REPLACEMENT PARTS:

Ref.	PART NO.	DESCRIPTION
A	CV3002CC	Drive Assembly, I Series
B	CV3186	Power Cord with Transformer, Clack Impression Valve
C	CV3003	Meter and Cable Assembly
D	CV3006	Bypass Valve, I Series, less I/O fittings
1	CV3175CC-01BK	Black Front Cover, I Series
2	CV3107-01	Drive Motor, I Series
3	CV3108CC	Circuit Board, I Series Valve
4	CV3004	Drive Cap Assembly
5	CV3135	O-ring, -228
6	CV3011	Piston Assembly, I Series
7	CV3174	Brine Valve, I Series
8	CV3005	Seal Cartridge Assembly, I Series
9	CV3178	Back plate for I Series valve
10	CV3180	Base o-ring for I Series valve, -337
11	CV3105	O-ring, -215
12	CV3177-01	Injector screen, I Series
13	CV3010-1Z	Injector Assembly Plug
14	CV3010-1E CV3010-1F	Clack Injector, White (for 1.5 cubic feet and less) Clack Injector, Dark Blue (for 2 cubic feet and higher)
15	CV3150	Split Ring Retainer
16	CV3151	Nut, 1" Quick Connect
17	CH4615	Elbow Locking Clip
18	CV3163	O-ring, -019
19	CV3165-01	Refill Flow Control Retainer
20	CH4613	Brine Fitting, 3/8" Tube
21	GL463412	3/4" Female NPT x 1/2" Barb Elbow
22	CV3158-01	Drain Elbow 3/4" Male Assy
23	CV3159-01	DLFC Retainer Assembly
24	CV3162-010 CV3162-013 CV3162-017 CV3162-022 CV3162-032	Drain Line Flow Control Button: Flow Control Washer, 1.0 GPM (for I10948) Flow Control Washer, 1.3 GPM (for INT1035) Flow Control Washer, 1.7 GPM (for I0844 and I0948) Flow Control Washer, 2.2 GPM (for IC0835, IC1035, I1054, and I11248) Flow Control Washer, 3.2 GPM (for I1248 and I1365)

INSTALLATION FITTING ASSEMBLIES:

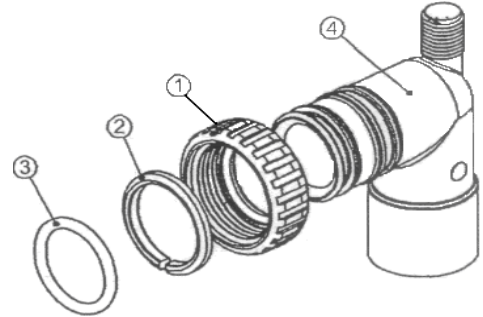
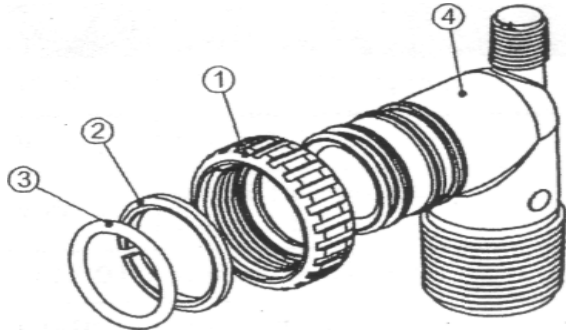

1" PVC MALE NPT ELBOW

Item No.	Part No.	Description	Qty
	CV3007	1" PVC male NPT elbow assy.	2
1	CV3151	Nut, 1" quick connect	2
2	CV3150	Split ring	2
3	CV3105	O-ring 215	2
4	CV3149	Fitting	2

3/4" & 1" PVC SOLVENT ELBOW

Item No.	Part No.	Description	Qty
	CV3007-01	3/4" & 1" PVC solvent elbow assy.	2
1	CV3151	Nut, 1" quick connect	2
2	CV3150	Split ring	2
3	CV3105	O-ring 215	2
4	CV3189	Fitting	2

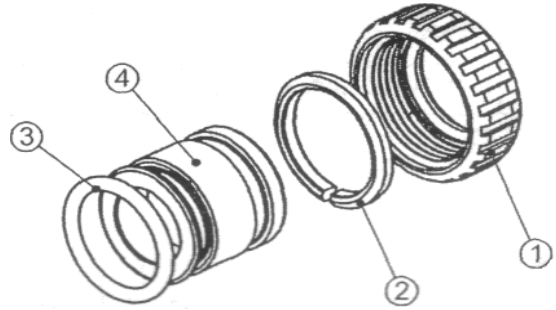
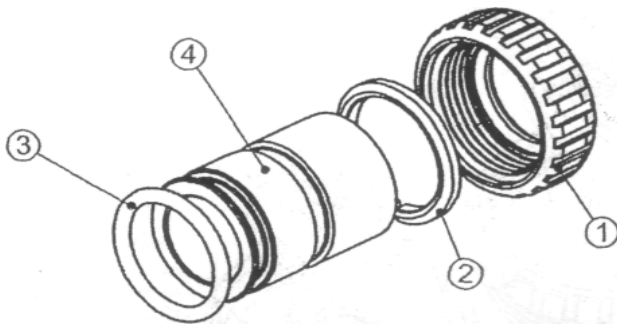

1" BRASS SWEAT

Item No.	Part No.	Description	Qty
	CV3007-02	1" brass sweat assembly	2
1	CV3151	Nut, 1" quick connect	2
2	CV3150	Split ring	2
3	CV3105	O-ring 215	2
4	CV3188	Fitting	2

3/4" BRASS SWEAT

Item No.	Part No.	Description	Qty
	CV3007-03	3/4" brass sweat assembly	2
1	CV3151	Nut, 1" quick connect	2
2	CV3150	Split ring	2
3	CV3105	O-ring 215	2
4	CV3188-01	Fitting	2

INSTALLATION FITTING ASSEMBLIES:

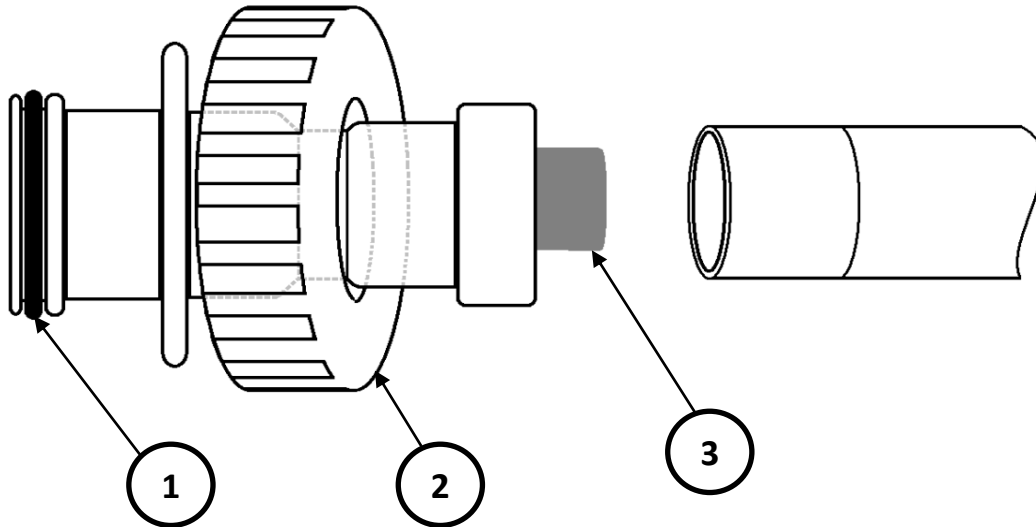

3/4" COPPER Q-TITE CONNECTOR			
Item No.	Part No.	Description	Qty
	QT-34 KIT	Fittings, Items # 1-3	2
1	CV3105	O-ring 215	2
2	CV3151	Nut, 1" quick connect	2
3	PEX-L	PEX tubing insert	2

SERVICE WRENCH - CV3193

Although no tools are necessary to assemble or disassemble the valve, the *Service Wrench*, (shown in various positions on the valve) is available to aid in assembly or disassembly.

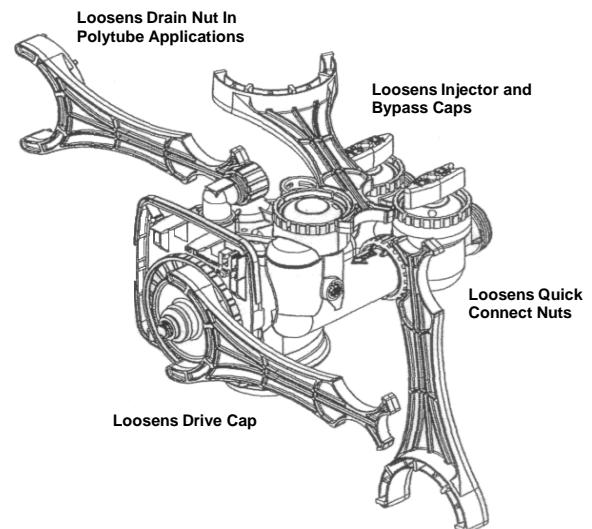

SPECIFICATIONS:

	UNIT MODEL NUMBER ¹						
	IC0835	IC1035	I0844	I0948	I1054	I1248	I1365
MEDIA VOLUME (ft³)	0.75	1.0	0.75	1.0	1.5	2.0	2.5
CAPACITY (grains)							
@Minimum Salt Setting (6#/ft ³)	13,500	18,000	13,500	18,000	27,000	36,000	45,000
@Factory Salt Setting (9#/ft ³)	15,750	21,000	15,750	21,000	31,500	42,000	52,500
@Maximum Salt Setting (15#/ft ³)	24,000	32,000	24,000	32,000	48,000	64,000	80,000
SERVICE FLOW RATES (gpm)							
Continuous	8	10	8	10	12	15	18
Peak	12	15	12	15	18	20	22
PRESSURE LOSS (psi)²							
@ Continuous Flow Rate	5	7	7	8	9	10	12
@ Peak Flow Rate	12	20	18	20	20	22	24
REGENERATION FLOW RATES (gpm)							
Backwash	2.2	2.2	1.3	1.7	2.2	3.2	4.2
Brine Draw and Slow Rinse	0.27	0.27	0.27	0.27	0.27	0.38	0.38
Rapid Rinse	2.2	2.2	1.3	1.7	2.2	3.2	4.2
FACTORY REGENERATION SETTINGS							
Brine Fill (# of salt)	6	9	6	9	13.5	18	22.5
Softening (minutes)	90	90	90	90	90	90	90
Backwash (minutes)	6	6	6	6	8	10	12
Brine & Rinse (minutes)	45	45	45	45	50	55	60
Rapid Rinse (minutes)	4	4	4	4	6	6	6
Total Water Used (gallons)	34	34	25	29	44	72	98
DIMENSIONS (in.)							
Mineral Tank (diameter x height)	10 x 35	10 x 35	8 x 44	9 x 48	10 x 54	12 x 48	13 x 54
Brine Tank (diameter x height)	11 x 11 x 34	11 x 11 x 34	18 x 33	18 x 33	18 x 33	18 x 33	18 x 33
Overall (length x width x height)	11 x 21 x 43	11 x 21 x 43	18 x 26 x 52	18 x 27 x 56	18 x 28 x 62	18 x 30 x 56	18 x 31 x 62

GENERAL REQUIREMENTS:

Water Temperature	33°F - 100°F
Water Pressure	25 - 100 psi
Electrical Requirements	110v/60hz
Electrical Current Draw	0.5 amps
Maximum Iron Concentration ³	≤ 2.0 ppm

Notes:

1. Unit models listed include 3/4" Q-Tite plumbing connections. If 1" elbow connections are required use "-1" as suffix to the unit model number (i.e. I0948-1).
2. Pressure loss information is approximate. Actual pressure loss may vary depending on water quality, temperature, gallons used since last regeneration, etc.
3. Water softeners can be expected to remove reasonable amounts of clear water (ferrous) iron only. For best results an iron filter is recommended. Anytime red water (ferric) iron or iron bacteria is present an iron filter is required.

SPECIFICATIONS:

	UNIT MODEL NUMBER ¹		
	INT1035	II0948	II1248
MEDIA VOLUME (ft³)	1.0	1.0	2.0
CAPACITY (grains)			
@Minimum Salt Setting (6#/ft ³)	18,000	18,000	36,000
@Factory Salt Setting (9#/ft ³)	21,000	21,000	42,000
@Maximum Salt Setting (15#/ft ³)	34,000	34,000	68,000
SERVICE FLOW RATES (gpm)			
Continuous	10	10	15
Peak	15	15	20
PRESSURE LOSS (psi)²			
@ Continuous Flow Rate	7	8	10
@ Peak Flow Rate	20	20	22
REGENERATION FLOW RATES (gpm)			
Backwash	1.3	1.0	2.2
Brine Draw and Slow Rinse	0.27	0.27	0.38
Rapid Rinse	1.3	1.0	2.2
FACTORY REGENERATION SETTINGS			
Brine Fill (# of salt)	9	9	18
Softening (minutes)	90	90	90
Backwash (minutes)	6	6	10
Brine & Rinse (minutes)	45	45	55
Rapid Rinse (minutes)	4	4	6
Total Water Used (gallons)	25	22	56
DIMENSIONS (in.)			
Mineral Tank (diameter x height)	10 x 35	9 x 48	12 x 48
Brine Tank (diameter x height)	11 x 11 x 34	18 x 33	18 x 33
Overall (length x width x height)	11 x 22 x 43	18 x 27 x 56	18 x 30 x 56

GENERAL REQUIREMENTS:	Water Temperature	33°F - 100°F
	Water Pressure	25 - 100 psi
	Electrical Requirements	110v/60hz
	Electrical Current Draw	0.5 amps
	Maximum Iron Concentration ³	≤ 4.0 ppm

Notes:

1. Unit models listed include 3/4" Q-Tite plumbing connections. If 1" elbow connections are required use "-1" as suffix to the unit model number (i.e. I0948-1).
2. Pressure loss information is approximate. Actual pressure loss may vary depending on water quality, temperature, gallons used since last regeneration, etc.
3. Water softeners can be expected to remove reasonable amounts of clear water (ferrous) iron only. For best results an iron filter is recommended. Anytime red water (ferric) iron or iron bacteria is present an iron filter is required.

QUICK REFERENCE GUIDE:

GENERAL OPERATION

When the system is operating, one of three displays will be shown: Time of day, gallons per minute, or gallons of treated water available. Pressing NEXT will toggle between the three choices.

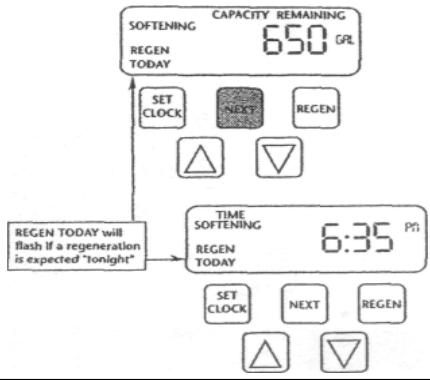

MANUAL REGENERATION

NOTE: For softeners, if brine tank does not contain salt, fill with salt and wait at least 1.5 hours before regeneration. If you need to initiate a manual regeneration, either immediately, or the same night at the preprogrammed time for regeneration (typically 2:00 AM), complete the following steps:

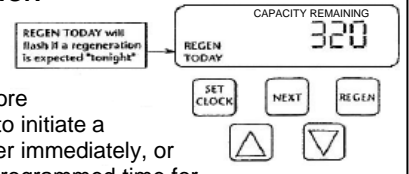

For Immediate Regeneration: Press and hold REGEN until valve motor starts (typically 3 seconds).

For Regeneration the same night: Press and release REGEN (notice that flashing "REGEN TODAY" appears.)

TO SET TIME OF DAY

In the event of a prolonged power outage, time of day flashes, indicating that this needs to be reset. All other information will be stored in memory no matter how long the power outage. Please complete the steps as shown to the right. To access this mode, press SET CLOCK

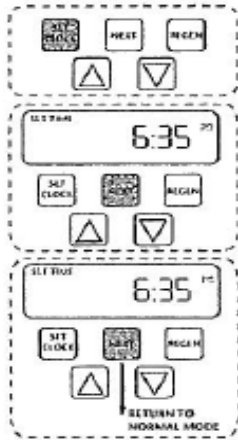

1. Accessed by pressing SET CLOCK
2. Adjust hours with ▲ and ▼ buttons, AM/PM toggles at 12
3. Press NEXT
4. Adjust minutes with ▲ and ▼ buttons
5. Press NEXT to complete and return to normal operation.

ERROR

If the display toggles between "Error" and an error code (i.e. a number), call a service technician and report the error code.

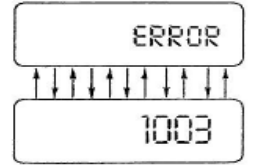

BYPASS VALVE OPERATION

To shut-off water to the system, please position arrow handles as shown in the bypass operation diagram below. If your valve doesn't look like the diagram below, contact your service technician for instructions on how to shut off water.

NORMAL OPERATION

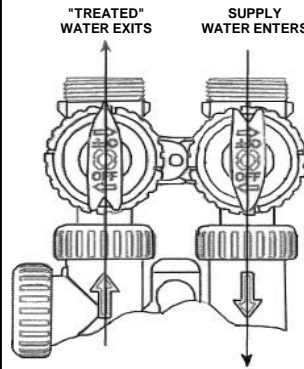

BYPASS OPERATION

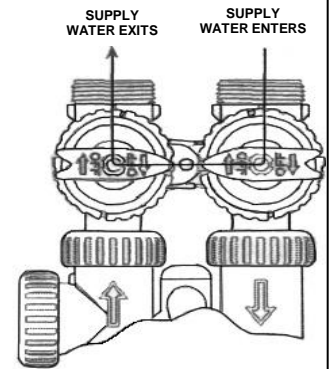

ADJUST HARDNESS, DAYS BETWEEN REGENERATION, OR TIME OF REGENERATION

For initial set-up or to make adjustments, please complete the steps as shown to the right. Access this mode by pressing NEXT and ▲ button simultaneously.

NOTE: Hardness display shows "-nA-" if used as a filter. If other displays do not appear, refer to manual.

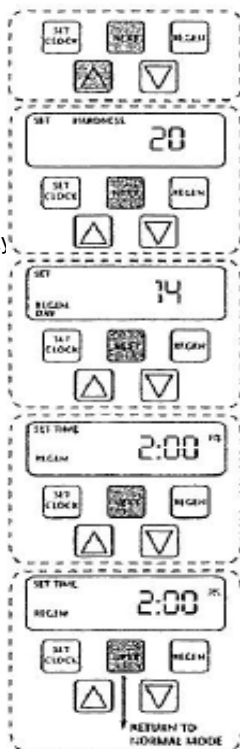

1. Accessed by pressing NEXT and ▲ button simultaneously
2. Adjust hardness setting ▲ and ▼ buttons
3. Press NEXT
4. Adjust days between regenerations using ▲ and ▼ buttons
5. Press NEXT
6. Adjust time of regeneration hour with ▲ and ▼ buttons, AM/PM toggles at 12.
7. Press NEXT
8. Adjust time of regeneration minutes with ▲ and ▼ buttons.
9. Press NEXT to complete and return to normal operation.



12630 US Highway 33 North
Churubusco, IN 46723
Phone: (260)693-1972 Fax: (260)693-0602

TEN YEAR LIMITED WARRANTY

WARRANTY — First Sales, LLC warrants this water conditioner against any defects that are due to faulty material or workmanship during the warranty period. This warranty does not include damage to the product resulting from accident, neglect, misuse, misapplication, alteration, installation or operation contrary to printed instructions, or damage caused by freezing, fire, flood, or Acts of God. From the original date of consumer purchase, we will repair or replace, at our discretion, any part found to be defective within the warranty period described below. Purchaser is responsible for any shipping cost to our facility and any local labor charges.

- One year on the entire water conditioner
- Five years on the control valve
- Five years on the salt storage tank
- Ten years on the mineral tank

GENERAL CONDITIONS — Should a defect or malfunction occur, contact the dealer that you purchased the product from. If you are unable to contact the dealer, contact First Sales, LLC at (260) 693-1972. We will require a full description of the problem, model number, serial number, date of purchase, and selling dealer's business name and address.

We assume no warranty liability in connection with this water conditioner other than specified herein. This warranty is in lieu of all other warranties, expressed or implied, including warranties of fitness for a particular purpose. We do not authorize any person or representative to assume for us any other obligations on the sale of this water conditioner.

FILL IN AND KEEP FOR YOUR RECORDS

Original Purchaser	Date of Purchase	Model #	Serial #
Address of Original Installation		City	State
Dealer Purchased From	Dealer Address	City	State

First Sales, LLC
12630 U.S. 33 North, Churubusco, IN 46723