



Installation Instructions and Owner's Manual

HEX, IX & INTX Series **Water Softener System**



AVID Water Systems
12630 US Highway 33 N
Churubusco, IN 46723
Phone (260) 693-1972 Fax (260) 693-0602

Table of Contents

Pre-installation Instructions	Page 2
General Installation Instructions	Page 3
Bypass Valve	Page 4
Installation Instructions	Page 5
Control Valve Programming – Set Time-of-Day	Page 7
Control Valve Programming – Initial Settings	Page 8
Control Valve Operating Displays	Page 11
Quick Reference Guide	Page 12
Specifications	Page 13
Component Parts Breakdown	Page 15
Component Parts List	Page 16
Control Valve Breakdown	Page 17
Control Valve Parts List	Page 18
Installation Fitting Assemblies	Page 19
Troubleshooting Guide	Page 22
Ten Year Limited Warranty	Page 25

Pre-installation Instructions

Description of the softener

The softener system includes a mineral tank (with gravel, distributor and softener resin), brine tank (with salt shelf, brine well, brine tank lid and safety brine valve), and a meter initiated electronic backwashing control valve with bypass and brine line.

Successful Application

Softeners are designed to remove hardness minerals (calcium and magnesium) from water by the process of ion exchange. They may also remove small amounts of “clear water” iron (2 ppm or less). Softeners are not designed to remove “red water” iron or bacterial iron. If greater levels of iron, “red water” or iron bacteria are present, an iron filter (O3) must precede the softener. Softeners are not designed to remove particulates. If there is any sediment or turbidity present in the water, a backwashing filter (FB) with appropriate media must precede the softener. Only specialty tannin softeners are designed to remove tannins and the yellow to tea color from water. Softeners will not reduce hydrogen sulfide (“rotten egg” odor).

Time of Regeneration

Periodically the control valve will go through regeneration. Regeneration is factory preset to 2:00 A.M. The time of regeneration may be changed if needed (see programming procedures on page 8).

Location Considerations

The proper location to install the softener will ensure optimum performance and satisfactory water quality. The following factors should be considered in selecting the location of this system.

1. The softener must be installed after the pressure tank (private well system only).
2. The softener should be installed after any iron filter and/or other backwashing filter.
3. If chlorine is present in the supply water a whole house carbon filter should be installed before the softener.
4. The system must not be subject to freezing temperatures
5. Ensure that any in-line filter installed prior to the softener does not restrict the flow or pressure required to backwash the softener.
6. The system should be installed as close as possible (preferably within 15') to an adequate floor or laundry drain capable of handling the backwash cycle volume and flow rate (refer to unit specifications on pages 13-14). An air gap should be provided between the drain line and plumbing drain.
7. All water conditioning equipment should be installed at least 10' prior to the water heater. Water temperatures exceeding 100°F can damage the internal components of the control valve and mineral tank. An expansion tank may need to be installed in the line to the water heater in order to allow for thermal expansion and comply with local plumbing codes.
8. Appliances requiring extended periods of continuous or high flow water use (i.e. geothermal heat pumps, swimming pools, lawn irrigation, outside hose bibs, etc.) should bypass all water conditioning equipment unless the equipment has been specifically designed for that purpose.

General Installation Instructions

GENERAL INSTALLATION & SERVICE WARNINGS

The softener is not designed to support the weight of plumbing.

Do not use Vaseline, oils, other hydrocarbon lubricants or spray silicone anywhere. A silicone lubricant may be used on black "O" Rings, but is not necessary. *Avoid any type of lubricants, including silicone, on red or clear lip seals.*

Do not use pipe dope or other sealants on threads. Teflon® tape must be used on the threads of the 1" NPT inlet and outlet and on the threads for the drain line connection. Teflon® tape is not used on the nut connections or caps because "O" Ring seals are used.

The nuts and caps are designed to be unscrewed or tightened by hand or with the special plastic Service Wrench, (CV3193, not included). If necessary, pliers can be used to unscrew the nut or cap. Do not use a pipe wrench to tighten nuts or caps. *Do not place screwdriver in slots on caps and/or tap with a hammer.*

NOTE: If the plumbing system is used as the ground leg of the electric supply, continuity should be maintained by installing ground straps around any non-conductive plastic piping or bypass used in the installation.

Make sure the softener is not installed backwards. The softener will not function properly if installed backwards and softener resin may be forced into the water lines. Arrows molded into the valve body indicate the direction of flow.

Site Requirements

- water pressure -- 25-100 psi (1.7 – 6.9 bar)
- water temperature -- 33-100°F (0.5-37.7°C)
- electrical -- 115/120 V, 60 Hz uninterrupted outlet dry locations only
- the tank should be on a firm level surface

Typical Installation

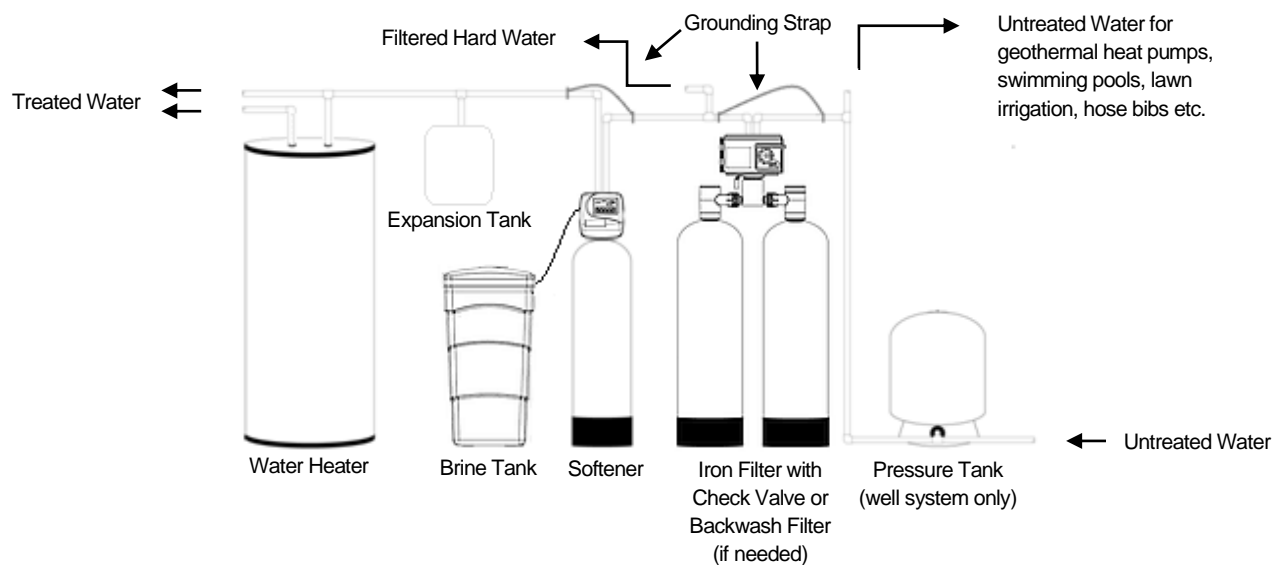

FIGURE 1: Typical Installation

Bypass Valve

The bypass valve is used to isolate the control valve from the plumbing system's water pressure in order to perform control valve repairs or maintenance. The 1" full flow bypass valve incorporates four positions including a diagnostic position that allows a service technician to have pressure to test a system while providing untreated bypass water to the building. Be sure to install bypass valve onto main control valve, before beginning plumbing or make provisions in the plumbing system for a bypass. The bypass body and rotors are glass filled Noryl® and the nuts and caps are glass filled polypropylene. All seals are self-lubricating EPDM to help prevent valve seizing after long periods of non-use. Internal "O" Rings can easily be replaced if service is required. The bypass consists of two interchangeable plug valves that are operated independently by red arrow shaped handles. The handles identify the direction of flow. The plug valves enable the bypass valve to operate in four positions.

1. **Normal Operation Position:** The inlet and outlet handles point in the direction of flow indicated by the engraved arrows on the control valve. Water flows through the control valve for normal operation of a water softener or filter. During the regeneration cycle this position provides regeneration water to the unit, while also providing untreated water to the distribution system (**Fig. 2**).
2. **Bypass Position:** The inlet and outlet handles point to the center of the bypass. The system is isolated from the water pressure in the plumbing system. Untreated water is supplied to the building (**Fig. 3**).
3. **Diagnostic Position:** The inlet handle points toward the control valve and the outlet handle points to the center of bypass valve. Untreated supply water is allowed to flow to the system and to the building, while not allowing water to exit from the system to the building (**Fig. 4**). This allows the service technician to draw brine and perform other tests without the test water going to the building.

NOTE: The system must be run through a rinse cycle before returning the bypass valve to the normal position.

4. **Shut Off Position:** The inlet handle points to the center of the bypass valve and the outlet handle points away from the control valve. The water is shut off to the building. The water treatment system will depressurize upon opening a tap in the building. A negative pressure in the building combined with the softener being in regeneration could cause a siphoning of brine into the building. If water is available on the outlet side of the softener it is an indication of water bypassing the system (**Fig. 5**)

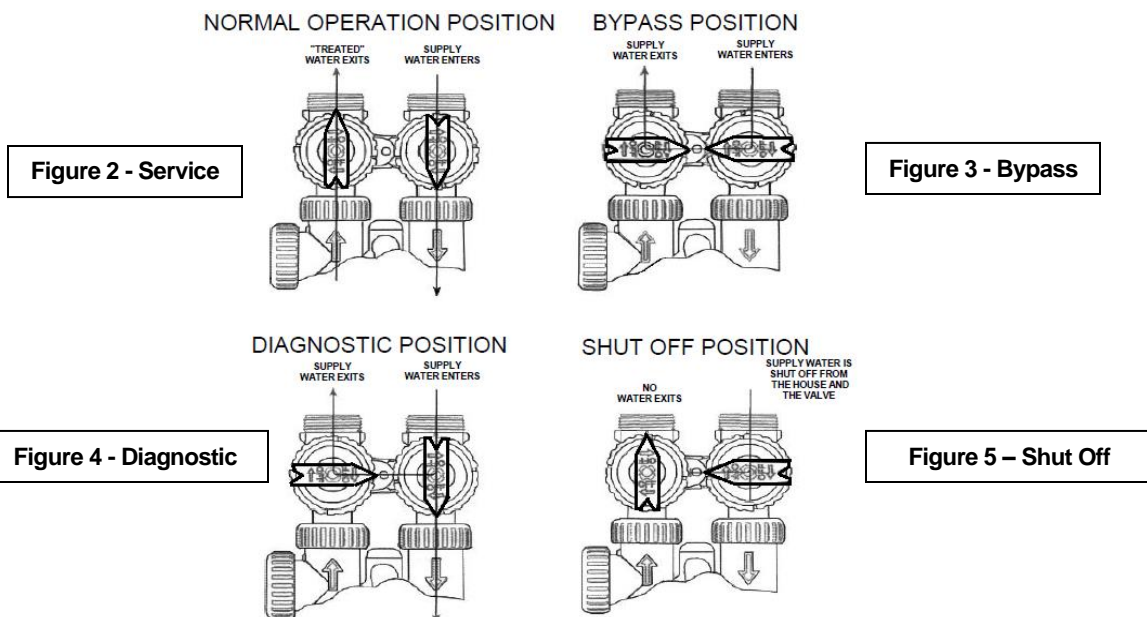

Installation Instructions

- STEP 1:** **Unpack softener**, making sure to remove entire contents of the shipping container prior to disposal.
- STEP 2:** **Install bypass valve** onto main control valve, before beginning plumbing. Make provisions to bypass outside hydrant and cold hard water lines at this time.
- STEP 3:** **Shut off all water** at main supply. On private well system, turn off power to pump and drain pressure tank. Make certain pressure is relieved from complete system by opening nearest faucet to drain system. **SHUT OFF FUEL / ELECTRICAL SUPPLY TO WATER HEATER.**
- STEP 4:** **Plumb the water supply line to the unit's bypass valve** inlet located at the right rear as you face the unit. There are a variety of installation fittings available. They are listed under Installation Fitting Assemblies, pages 19-21. When assembling the installation fitting package (inlet and outlet), connect the fitting to the plumbing system first and then attach the nut, split ring, and "O" Ring. Heat from soldering or solvent cements may damage the nut, split ring, or "O" Ring. Solder joints should be cool and solvent cements should be set before installing the nut, split ring, and "O" Ring. Avoid getting solder flux, primer, and solvent cement on any part of the "O" Rings, split rings, bypass valve, or control valve. If the building's electrical system is grounded to the plumbing, install a copper grounding strap from the inlet to the outlet pipe. Plumbing must be done in accordance with all applicable local codes. **MAKE CERTAIN WATER ENTERS THROUGH INLET AND DISCHARGES THROUGH OUTLET.**

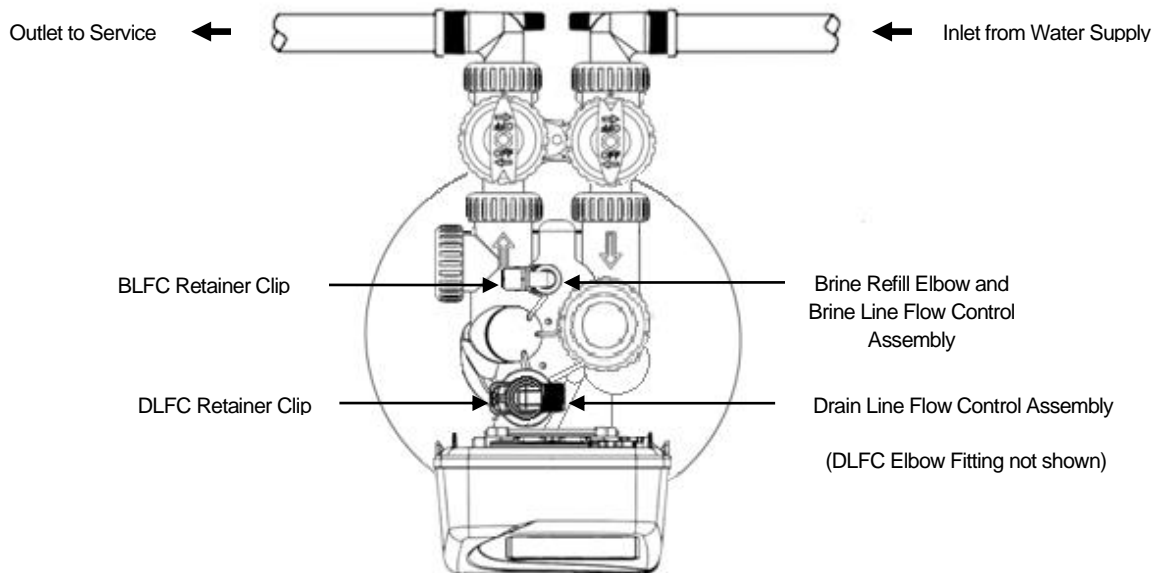

FIGURE 6: Top View of Control Valve with Bypass Installed

- STEP 5:** **Apply thread tape to DLFC Assembly.** Remove drain line flow control (DLFC) retainer clip (Figure 6) and remove the DLFC assembly from the valve body, (Figure 6). Unscrew drain line elbow (not shown) from DLFC. Apply thread tape to threads and re-attach the barbed drain line elbow. Reinsert DLFC assembly into the valve body, making certain it is **FULLY** inserted before replacing the retaining clip.

Installation Instructions (cont.)

- STEP 6:** **Install softener drain line.** Use polyethylene drain line provided (**NO VINYL TUBING!**) to run drain line from control valve barbed DLFC elbow fitting (Figure 6, Page 5, not shown) to floor drain or sump pit capable of handling the backwash rate of the filter (refer to specifications and flow rate on pages 13-14) or discard the barbed fitting and use 3/4" NPT fitting to connect a rigid pipe drain line (recommended). If backwash flow rate is greater than 7 gpm, use 3/4" drain line. There must be an air gap at the end of the drain line to prevent siphoning of waste water. Length of drain line should be 15' or less. **AVOID OVERHEAD DRAINS.**
- STEP 7:** **Connect brine line between the softener and safety brine valve.** Install the 3/8" O.D. polyethylene tube from the brine refill elbow (Figure 6, Page 5) to the safety brine valve (Figure 7) inside the brine tank. **DO NOT INSERT THE BRINE REFILL LINE INTO THE BRINE TANK OVERFLOW ELBOW FITTING. Do not put salt in the tank until STEP 24.**

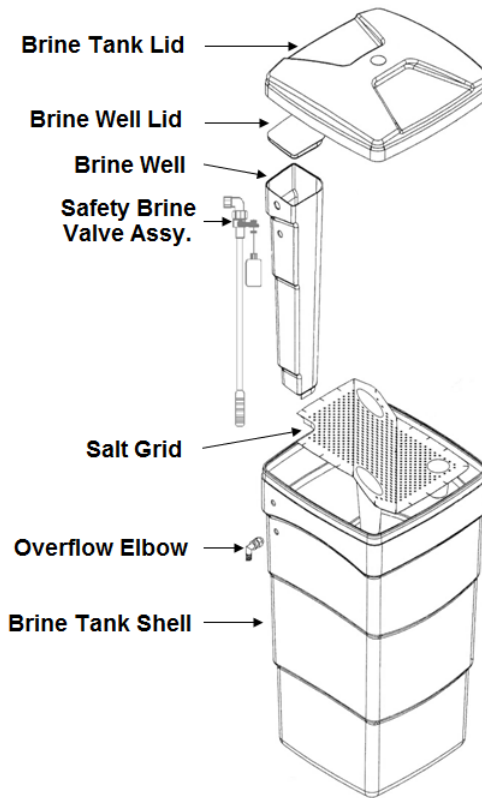

FIGURE 7: Brine Tank

- STEP 8:** **Install brine tank overflow drain line (not included).** An overflow drain line is recommended where a brine overflow could damage furnishings or the building structure. Your softener is equipped with a brine tank safety float (Figure 7) which greatly reduces the chance of an accidental brine overflow. In the event of a malfunction, however, an overflow line connection will direct the "overflow" to the drain instead of spilling on the floor where it could cause considerable damage. This fitting is an elbow on the side of the brine tank (Figure 7). Attach a length of 1/2" I.D. tubing to fitting and run to drain. Do not elevate overflow line higher than 3" below bottom of overflow fitting. **DO NOT "TIE" THIS TUBE INTO THE DRAIN LINE OF THE CONTROL VALVE AS IT WILL RESULT IN OVERFILLING THE BRINE TANK AND FLOODING.** The overflow line must be a direct, separate line from the brine tank overflow elbow to a drain or sump pit.

Installation Instructions (cont.)

STEP 9: Turn on water supply. **MAKE SURE THE BYPASS VALVE IS IN THE “BYPASS” POSITION** (Figure 3, Page 4) NOTE: the INLET and OUTLET knobs turn *clockwise* to close the port to the softener and *counter-clockwise* to open the port to the softener. Open the main supply valve or turn on power to the pump on private well systems. Check for leaks and correct as needed.

STEP 10: **Program control valve.** Plug the transformer of the control valve into an uninterrupted electrical outlet (not wired to a switch) and use the buttons on the front of the control valve to adjust the initial settings:

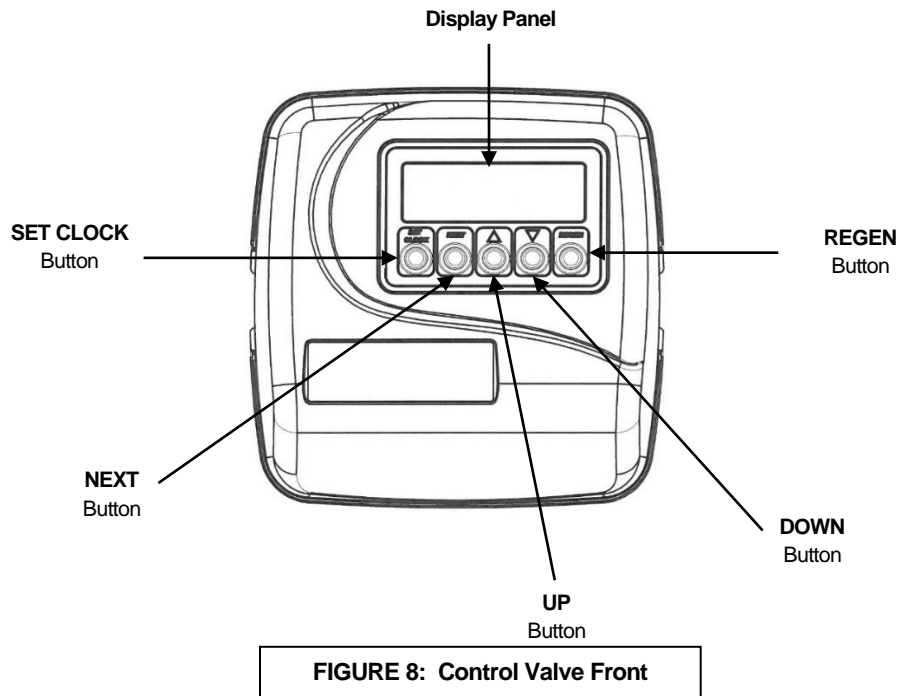

A) SET THE TIME OF DAY

1. Press the “SET CLOCK” button
 - a. The upper left of the display will show “SET TIME”
 - b. The hour will flash
2. Press the UP or DOWN buttons (triangle pointing up or down) until the correct combination of hour and “AM” or “P M” (NOTE: letter spacing as shown on the display) is reached to match the current time.
3. Press the “NEXT” button
 - a. The upper left of the display will show “SET TIME”
 - b. The minutes will flash
4. Press the UP or DOWN buttons until the minutes match the current time.
5. Press the “NEXT” button
 - a. The upper left of the display will show “TIME”
 - b. The current time of day will be shown on the right side of the display
 - c. Only the colon between the hour and minutes will be flashing.

Installation Instructions (cont.)

B) Enter Programming: The manufacturer has preset the unit so gallons between regenerations are automatically calculated after hardness is entered.

1. **Hardness:** Press “NEXT” and UP (triangle pointing up) buttons simultaneously for 3 seconds.
 - a. The upper left of the display will show “SET HARDNESS”
 - b. A number will flash (default 20).
2. Based on water analysis results (obtained either from a lab or in-field testing). Set the amount of hardness in grains per gallon using the UP or DOWN (triangle pointing up or down) buttons. The allowable range is from 1 to 150 in 1 grain increments. **Note: Increase the grains per gallon if soluble (“clear water”) iron and/or manganese is present (1 ppm iron = 3 gpg hardness and 1 ppm manganese = 5 gpg hardness).**
3. **Regeneration Days Override:** Press the “NEXT” button
 - a. The upper left of the display will show “SET”
 - b. The lower left of the display will show “REGEN” above and “DAY” below.
 - c. A number will flash (default 14)
4. Using the UP or DOWN (triangle pointing up or down) buttons, set the maximum number of days (default 14, recommended) the softener will go without initiating regeneration even if the unit still has capacity remaining based on water usage, hardness setting and capacity setting. The allowable range is 1 to 28 and OFF. If set to OFF, the unit will only regenerate based on water usage, hardness and capacity.
5. **Regeneration Time:** Press the “NEXT” button
 - a. The upper left of the display will show “SET TIME”
 - b. The middle left of the display will show “REGEN”
 - c. The hour will flash
6. **Regeneration Hour:** Using the UP or DOWN buttons, set the combination of hour of day and “AM” or “P M” (NOTE: letter spacing as shown on the display) that the BACKWASH cycle of regeneration should occur. Please note that regeneration will actually begin with the short (less than 10 minutes) Brine Fill cycle 2 hours prior to the time set here followed by 120 minutes (default) of inactivity to allow water in the brine tank to become saturated with salt.
7. Press the “NEXT” button
 - a. The upper left of the display will show “SET TIME”
 - b. The middle left of the display will show “REGEN”
 - c. The minutes will flash
8. **Regeneration Minutes:** Using the UP or DOWN buttons, set the minutes portion of the time when regeneration should occur.
9. **Exit Programming:** Press the “NEXT” button
 - a. The upper left of the display will show “TIME”
 - b. The current time of day will be shown on the right side of the display
 - c. Only the colon between the hour and minutes will be flashing

Installation Instructions (cont.)

- STEP 11:** **Initiate Manual Regeneration (Fill Cycle):** (NOTE: the bypass should be in the bypass position) Press and hold the “REGEN” button 3 seconds or until the word “Fill” appears in the lower right of the display and “REGEN” appears at the middle left of the display. The drive motor will run briefly and count-down timer will appear in the time-of-day position on the display. Press the “REGEN” button briefly. The control valve will advance to the next cycle.
- STEP 12:** **Softening Cycle:** “SOFTENING” will appear in the upper left of the display and “REGEN” in the middle left. Another count-down timer will appear in the time-of-day position of the display. Press the “REGEN” button to advance the control valve to the “BACKWASH” cycle.
- STEP 13:** **Backwash Cycle:** “BACKWASH” will be shown in the lower middle of the display and “REGEN” appears in the middle left of the display. Another count-down timer will appear in the time-of-day position. Unplug the transformer from the electrical outlet to keep the softener from advancing to the next cycle. Slowly turn the INLET knob of the bypass, counter-clockwise, to a point not more than half way between “Bypass” and “Service” positions (Figure 2, Page 4). Water will begin to fill the mineral tank from the bottom up, gently purging the air from the tank. When air stops escaping and only water flows to the drain; gradually turn the INLET knob of the bypass valve counter-clockwise until it is fully in “Service” position (Figure 2, Page 4). Then turn the OUTLET knob of the bypass valve counter-clockwise until it is fully in the “Service” position (Figure 2, Page 4). When the water flowing to drain runs clear, plug the transformer back into the electrical outlet. Press the “REGEN” button to advance to the “Brine Draw” cycle.
- STEP 14:** **Brine Cycle:** “BRINE” will appear in the lower right of the display, “REGEN” will show in the middle left of the display and a new count-down timer will flash alternating with the letters “dn”. Press “REGEN” to advance to the second “Backwash” cycle.
- STEP 15:** **Backwash Cycle 2:** “BACKWASH” will be shown in the lower middle of the display and “REGEN” appears in the middle left of the display. Another count-down timer will appear in the time-of-day position. Press “REGEN” to advance to the “Rinse” cycle.
- STEP 16:** **Rinse Cycle:** Another count-down timer will appear in the time-of-day position, “RINSE” will be shown in the lower middle of the display and “REGEN” appears in the middle left of the display. Press the “REGEN” button to exit manual regeneration.
- STEP 17:** **Exit Manual Regeneration:** The right side of the display will be blank and “SOFTENING” will flash in the upper left of the display, “REGEN” will appear in the middle left of the display and the drive motor will run for a few seconds until the current time-of-day is shown on the right side of the display and “TIME” is shown in the upper left of the display.
- STEP 18:** **Initiate Manual Regeneration (Fill Cycle):** (NOTE: bypass should be in service position) Press and hold the “REGEN” button 3 seconds or until the word “Fill” appears in the lower right of the display and “REGEN” appears at the middle left of the display. The drive motor will run briefly and count-down timer will appear in the time-of-day position on the display. Allow the cycle to complete and advance to the next step automatically. If water does not fill to a point above the top of the salt grid, add some water manually to have approximately 1 inch of water above the top level of the grid.

Installation Instructions (cont.)

- STEP 19:** **Softening Cycle:** “SOFTENING” will appear in the upper left of the display and “REGEN” in the middle left. Another count-down timer will appear in the time-of-day position of the display. Press the “REGEN” button to advance the control valve to the “BACKWASH” cycle.
- STEP 20:** **Backwash Cycle:** “BACKWASH” will be shown in the lower middle of the display and “REGEN” appears in the middle left of the display. Another count-down timer will appear in the time-of-day position. Press the “REGEN” button to advance to the “Brine Draw” cycle.
- STEP 21:** **Brine Cycle:** “BRINE” will appear in the lower right of the display, “REGEN” will show in the middle left of the display and a new count-down timer will flash alternating with the letters “dn”. Allow this cycle to run until the water in the brine tank is drawn below the top of the salt grid and then press “REGEN” briefly to advance to the second “Backwash” cycle.
- IMPORTANT:** If water is NOT drawn below the top of the grid within 10 – 20 minutes (depending on softener size); complete the next two steps of installation and refer to the “Brine Tank Overfill” section of Troubleshooting (page 22) to resolve this problem. Failure to do so will prevent the softener from functioning properly. Test the solution by returning to STEP 18 and proceeding from there.
- STEP 22:** **Backwash Cycle 2:** “BACKWASH” will be shown in the lower middle of the display and “REGEN” appears in the middle left of the display. Another count-down timer will appear in the time-of-day position. Press “REGEN” to advance to the “Rinse” cycle.
- STEP 23:** **Rinse Cycle:** Another count-down timer will appear in the time-of-day position, “RINSE” will be shown in the lower middle of the display and “REGEN” appears in the middle left of the display. Press the “REGEN” button to exit manual regeneration.
- STEP 24:** **Add salt to brine tank.** Fill the brine tank with salt. Any type of softening salt may be used.
- STEP 25:** **TURN ON FUEL / ELECTRICAL SUPPLY TO WATER HEATER.**

Control Valve Operating Displays

1. General Operation:

When the system is operating, one of two displays may be shown. Pressing *next* will alternate between displays. One of the displays is always the current time of day. The other display shows the current volume remaining in Gallons. Capacity remaining is the gallons that will be treated before the system goes through a regeneration cycle.

The user can switch between the displays as desired.

If the system has called for a regeneration that will occur at the preset time of regeneration, the words *REGEN TODAY* will appear on the display.

The softener has an installed water meter, the word "Softening" flashes on the display when water is being treated (i.e. water is flowing through the system).

2. Regeneration Mode:

Typically a system is set to regenerate at a time of no water use. If there is a demand for water when the system is regenerating, untreated water will be delivered. When the system begins to regenerate, the display will change to include information about the step of the regeneration process and the time remaining for that step to be completed. The system runs through the steps automatically and will reset itself to provide treated water when the regeneration has been completed.

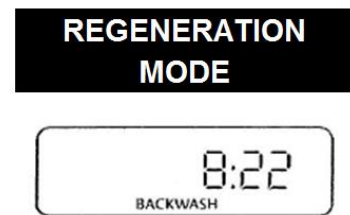

3. Manual Regeneration:

Sometimes there is a need to regenerate before the control valve calls for it. This may be needed if a period of heavy water use is anticipated or when the system has been operated without salt.

- To initiate a manual regeneration at the preset delayed regeneration time, press and release *regen*. The words "REGEN TODAY" will flash on the display to indicate that the system will regenerate at the preset delayed regeneration time.
- If you pressed the *regen* button in error, pressing the button again will cancel the command.
- To initiate an immediate manual regeneration, press and hold the *regen* button for three seconds. The system will begin to regenerate immediately. This command cannot be cancelled.

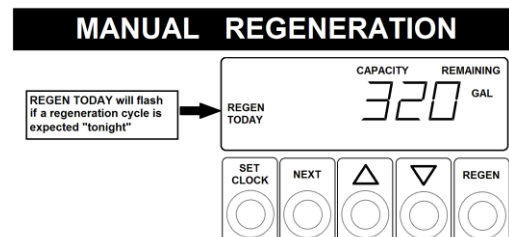

4. Power Loss:

If the power goes out for less than two hours, the system will automatically reset itself. If an extended power outage occurs, the time of day will flash on and off which indicated the time of day should be reset. The system will remember all other settings.

Error Message: If the word "ERROR" and a number are alternately flashing on the display, record the number and contact the dealer for help. This indicates that the control valve was not able to function properly.

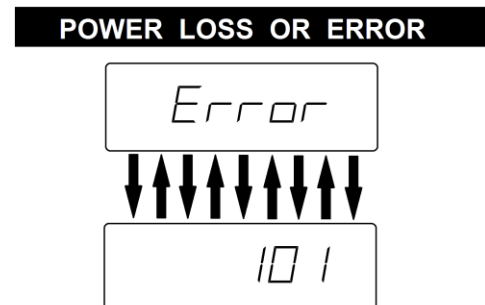

Quick Reference Guide

GENERAL OPERATION
When the system is operating either the Time of Day or Gallons of Treated Water Available will be displayed. Pressing NEXT will toggle between the two screens.

MANUAL REGENERATION
NOTE: For softeners, if brine tank does not contain salt, fill with salt before regeneration. If you need to initiate a manual regeneration, either immediately, or the same night at the preprogrammed time for regeneration (typically 2:00 AM), complete the following steps:

For Immediate Regeneration: Press and HOLD REGEN until valve motor starts (typically 3 seconds).

For Regeneration the same night: Press and RELEASE REGEN (notice that "REGEN TODAY" appears.)

TO SET TIME OF DAY
In the event of a prolonged power outage, time of day flashes, indicating that this needs to be reset. All other information will be stored in memory, no matter how long the power outage. Complete the steps as shown to the right.

1. Accessed by pressing SET CLOCK.
2. Adjust hours with Δ and ∇ buttons. AM/PM toggles at 12.
3. Press NEXT.
4. Adjust minutes with Δ and ∇ buttons.
5. Press NEXT to complete and return to normal operation.

ERROR
If the display toggles between "Error" and an error code (i.e. a number), call a service technician and report the error code.

BYPASS VALVE OPERATION
To shut off water to the system, please position arrow handles as shown in the bypass position diagram below. If your valve doesn't look like the diagram below, contact your service technician for instructions on how to shut off water.

NORMAL OPERATION
TREATED WATER OUTS SUPPLY WATER IN/OUTS

BYPASS POSITION
SUPPLY WATER OUTS SUPPLY WATER IN/OUTS

ADJUST HARDNESS, DAYS BETWEEN REGENERATION, OR TIME OF REGENERATION

For initial set-up or to make adjustments, please complete the steps as shown to the right.

NOTE: Hardness display shows "nA-" if used as a filter. If other displays do not appear, refer to full programming instructions.

1. Accessed by pressing NEXT and Δ .
2. Adjust hardness setting with Δ and ∇ buttons.
3. Press NEXT.
4. Adjust days between regenerations with Δ and ∇ buttons.
5. Press NEXT.
6. Adjust hours with Δ and ∇ buttons. AM/PM toggles at 12.
7. Press NEXT.
8. Adjust Δ in or ∇ with and buttons.
9. Press NEXT to complete and return to normal.

First Sales
12630 US 33 N
Churubusco, IN 46723
Phone: (260)693-1972 Fax: (260)693-0602

Specifications

Description	Model Numbers				
	IX0844-1	IX0948-1	IX1054-1	IX1248-1	IX1354-1
MEDIA VOLUME ft ³	0.75	1.0	1.5	2.0	2.5
CAPACITY, grains					
@Factory Salt @ 9lb/ft ³ (146 g/L)	18,000	24,000	36,000	48,000	60,000
@Max. Salt @ 15lb/ft ³ (243 g/L)	22,500	30,000	45,000	60,000	75,000
Operating Flow Rate, gpm					
Continuous (3 gpm/ft ³)	2	3	5	6	8
Service (8 gpm/ft ³ , <= 15 psi drop)	6	8	12	16	18
Peak (Max. 20 psi drop)	16	18	18	21	21
Pressure Loss psi					
@ Continuous Flow Rate	2	2	4	3	5
@ Service Flow Rate	6	7	11	13	15
@ Peak Flow Rate	19	20	20	19	19
Regen. Flow Rates, gpm					
Backwash & Rapid Rinse	1.7	2.7	3.2	4.2	4.2
Brine Draw / Rinse	0.38 / 0.5	0.38 / 0.5	0.38 / 0.5	0.38 / 0.5	0.38 / 0.5
Service Pipe Size, in.	1"	1"	1"	1"	1"
Factory Regeneration Settings					
Brine Tank Fill (lbs of salt)	6	9	13.5	18	22.5
Softening (minutes dissolving salt)	120	120	120	120	120
Backwash (minutes)	8	8	8	8	8
Brine Draw & Rinse (minutes)	60	60	60	60	60
Backwash (minutes)	8	8	8	8	8
Rapid Rinse (minutes)	4	4	4	4	4
Total Water Used, gallons	64	81	94	114	114
Dimensions in.					
Mineral Tank, diameter x height	8 x 44	9 x 48	10 x 54	12 x 48	13 x 54
Brine Tank, diameter x height	18 x 33	18 x 33	18 x 33	18 x 33	18 x 33
Overall, length x width x height	18 x 26 x 52	18 x 27 x 56	18 x 28 x 62	18 x 30 x 56	18 x 31 x 62
Approximate Ship Wt., lbs.	88	104	137	162	213

Description	Model Numbers				
	ICX0835-1	ICX1035-1	INTX1035-1	IIX0948-1	IIX1248-1
Resin Volume, cu. ft.	0.75	1.0	1.0	1.0	2.0
Capacity, grains					
@Factory Salt @ 9lb/ft ³ (146 g/L)	18,000	24,000	24,000	24,000	48,000
@Max. Salt @ 15lb/ft ³ (243 g/L)	22,500	30,000	30,000	30,000	60,000
Gravel Underbed, lbs.	20	20	20	20	25
Operating Flow Rate, gpm					
Continuous (3 gpm/ft ³)	2	3	2	2	4
Service (8 gpm/ft ³ , <= 15 psi drop) * (5 gpm/ft ² , <= 15 psi drop)	6	8	8	5*	10*
Peak (Max. 20 psi drop)	20	21	18	18	21
Pressure Loss psi (kPa)					
@ Continuous Flow Rate	1	2	1	1	2
@ Service Flow Rate	4	5	4	5	9
@ Peak Flow Rate	19	19	19	20	19
Regen. Flow Rates, gpm					
Backwash & Rapid Rinse	2.7	3.2	3.2	2.7	4.2
Brine Draw and Rinse	0.38 / 0.5	0.38 / 0.5	0.38 / 0.5	0.38 / 0.5	0.38 / 0.5
Service Pipe Size, in.	1"	1"	1"	1"	1"
Factory Regeneration Settings					
Brine Tank Fill (lbs of salt)	6	9	9	9	18
Softening (minutes dissolving salt)	120	120	120	120	120
Backwash (minutes)	8	8	8	8	8
Brine Draw & Rinse (minutes)	60	60	60	60	60
Backwash (minutes)	8	8	8	8	8
Rapid Rinse (minutes)	4	4	4	4	4
Total Water Used, gallons	81	94	94	81	114
Dimensions in.					
Mineral Tank, diameter x height	10 x 35	10 x 35	10 x 35	9 x 48	12 x 48
Brine Tank, w x d x h	13 x 13 x 35	13 x 13 x 35	13 x 13 x 35	18 x 33	18 x 33
Overall, length x width x height	16 x 23 x 43	16 x 23 x 43	13 x 22 x 43	18 x 27 x 56	18 x 30 x 56
Approximate Ship Wt., lbs.	83	94	102	104	162

Specifications (cont.)

Description	Model Numbers						
	HECX0935-1	HECX1035-1	HEX0844-1	HEX0948-1	HEX1054-1	HEX1248-1	HEX1354-1
Media Volume, ft³	0.75	1.0	0.75	1.0	1.5	2.0	2.5
Capacity, grains							
@ Factory Salt – 6lb/ft ³	16,500	22,000	16,500	22,000	33,000	44,000	55,000
@ Max. Salt – 15lb/ft ³	23,250	31,000	23,250	31,000	46,500	62,000	93,000
Operating Flow Rate, gpm							
Continuous (3 gpm / ft ³)	2	3	2	3	5	6	8
Service (8 gpm / ft ³ , <=15 psi drop)	6	8	6	8	12	16	18
Peak (Max. 20 psi drop)	20	21	16	18	18	21	21
Pressure Loss psi							
@ Continuous Flow Rate	1	2	2	2	4	3	5
@ Service Flow Rate	4	5	6	7	11	13	15
@ Peak Flow Rate	19	19	19	20	20	19	19
Regen. Flow Rates, gpm							
Backwash & Rapid Rinse	2.7	3.2	1.7	2.7	3.2	4.2	4.2
Brine Draw and Rinse	0.38 / 0.5	0.38 / 0.5	0.38 / 0.5	0.38 / 0.5	0.38 / 0.5	0.38 / 0.5	0.38 / 0.5
Service Pipe Size, in.	1"	1"	1"	1"	1"	1"	1"
Factory Regeneration Settings							
Brine Tank Fill (lbs of salt)	4.7	6	4.7	6	9	12	15
Softening (minutes dissolving salt)	120	120	120	120	120	120	120
Backwash (minutes)	6	6	6	6	6	6	6
Brine Draw & Rinse (minutes)	45	45	45	45	45	45	45
Backwash (minutes)	3	3	3	3	3	3	3
Rapid Rinse (minutes)	3	3	3	3	3	3	3
Total Water Used, gallons	55	61	43	55	61	73	73
Dimensions in.							
Mineral Tank, diameter x height	10 x 35	10 x 35	8 x 44	9 x 48	10 x 54	12 x 48	13 x 54
Brine Tank, diameter x height	13 x 13 x 35	13 x 13 x 35	18 x 33	18 x 33	18 x 33	18 x 33	18 x 33
Overall, length x width x height	16 x 23 x 43	16 x 23 x 43	18 x 26 x 52	18 x 27 x 56	18 x 28 x 62	18 x 30 x 56	18 x 31 x 62
Approximate Ship Wt., lbs.	82	94	93	104	137	162	213

Component Parts Breakdown

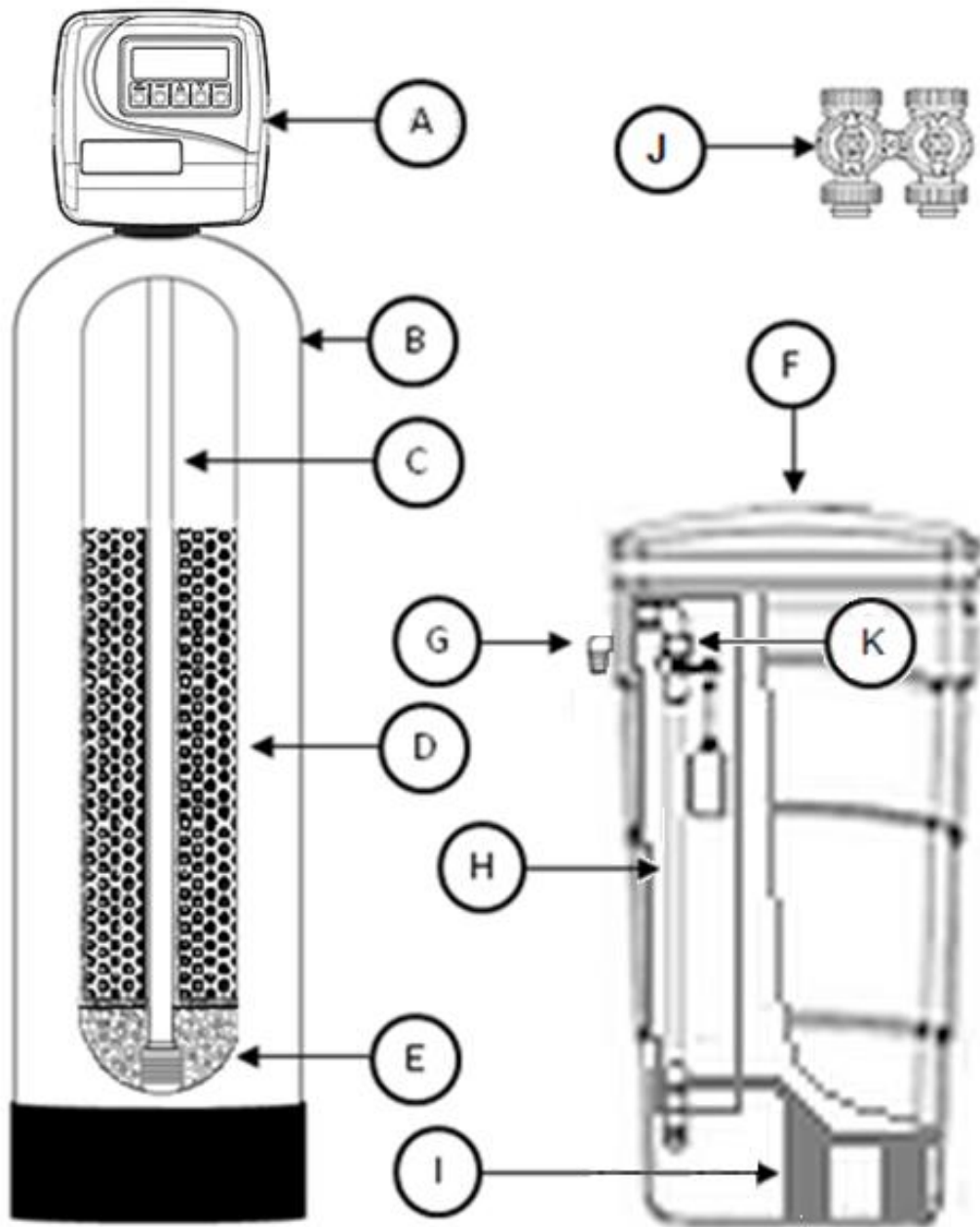

Component Parts List

REF	DESCRIPTION	MODEL NUMBER				
		IX0844-1	IX0948-1	IX1054-1	IX1248-1	IX1354-1
A*	Control Valve	IX0844 Vlv Assy L/BP	IX0948 Vlv Assy L/BP	IX1054 Vlv Assy L/BP	IX1248 Vlv Assy L/BP	IX1354 Vlv Assy L/BP
B	Mineral Tank	MTP0844GR	MTP0948GR	MTP1054GR	MTP1248GR	MTP1354N
C	Distributor	D100S-48	D100S-48	D100S-54	D100S-48	D100S-54
D	Resin	1 ½ - H05P	2 - H05P	3 - H05P	4 - H05P	5 - H05P
E	1/4" x 1/8 gravel	QC20	QC20	QC20	QC25	2 - QC20
F	Brine Tank Assy.	BTSQ1833ASSY	BTSQ1833ASSY	BTSQ1833ASSY	BTSQ1833ASSY	BTSQ1833ASSY
G	Overflow Elbow	BT-OVERFLO	BT-OVERFLO	BT-OVERFLO	BT-OVERFLO	BT-OVERFLO
H	Safety Brine Valve	SBV14ASSY	SBV14ASSY	SBV14ASSY	SBV14ASSY	SBV14ASSY
I	Salt Platform	BTSG18SQ	BTSG18SQ	BTSG18SQ	BTSG18SQ	BTSG18SQ
J**	Bypass Valve Less Fittings	CV3006	CV3006	CV3006	CV3006	CV3006
K	Elbow Locking Clip	FC103	FC103	FC103	FC103	FC103

REF	DESCRIPTION	MODEL NUMBER				
		ICX0835-1	ICX1035-1	INTX1035-1	IIX0948-1	IIX1248-1
A*	Control Valve	ICX0835 Vlv Assy L/BP	ICX1035 Vlv Assy L/BP	INTX1035 Vlv Assy L/BP	IIX0948 Vlv Assy L/BP	IIX1248 Vlv Assy L/BP
B	Mineral Tank	MTP0935GR	MTP1035GR	MTP1035GR	MTP0948GR	MTP1248GR
C	Distributor	D100S-48	D100S-48	D100S-48	D100S-48	D100S-48
D	Resin	1 ½ - H05P	2 - H05P	2 - H05P	4 - H05P	4 - H05P
E	1/4" x 1/8 gravel	QC20	QC20	QC20	QC20	QC25
F	Brine Tank Assy.	BT1234ASSY	BT1234ASSY	BT1234ASSY	BTSQ1833ASSY	BTSQ1833ASSY
G	Overflow Elbow	BT-OVERFLO	BT-OVERFLO	BT-OVERFLO	BT-OVERFLO	BT-OVERFLO
H	Safety Brine Valve	SBV14ASSY	SBV14ASSY	SBV14ASSY	SBV14ASSY	SBV14ASSY
I	Salt Platform	BTSG12	BTSG12	BTSG12	BTSG18SQ	BTSG18SQ
J**	Bypass Valve Less Fittings	CV3006	CV3006	CV3006	CV3006	CV3006
K	Elbow Locking Clip	FC103	FC103	FC103	FC103	FC103

REF	DESCRIPTION	MODEL NUMBER						
		HEC0935-1	HEC1035-1	HE0844-1	HE0948-1	HE1054-1	HE1248-1	HE1354-1
A*	Control Valve	HECX0935 Vlv Assy L/BP	HECX1035 Vlv Assy L/BP	HEX0844 Vlv Assy L/BP	HEX0948 Vlv Assy L/BP	HEX1054 Vlv Assy L/BP	HEX1248 Vlv Assy L/BP	HEX1354 Vlv Assy L/BP
B	Mineral Tank	MTP0935GR	MTP1035GR	MTP0844GR	MTP0948GR	MTP1054GR	MTP1248GR	MTP1354N
C	Distributor	D100S-48	D100S-48	D100S-48	D100S-48	D100S-54	D100S-48	D100S-54
D	Resin	1.5 - UHE05P	2 - UHE05P	1.5 - UHE05P	2 - UHE05P	3 - UHE05P	4 - UHE05P	5 - UHE05P
E	1/4" x 1/8 gravel	QC20	QC20	QC20	QC20	QC20	QC25	2 - QC20
F	Brine Tank Assy.	BT1234ASSY	BT1234ASSY	BTSQ1833ASSY	BTSQ1833ASSY	BTSQ1833ASSY	BTSQ1833ASSY	BTSQ1833ASSY
G	Overflow Elbow	BT-OVERFLO	BT-OVERFLO	BT-OVERFLO	BT-OVERFLO	BT-OVERFLO	BT-OVERFLO	BT-OVERFLO
H	Safety Brine Valve	SBV14ASSY	SBV14ASSY	SBV14ASSY	SBV14ASSY	SBV14ASSY	SBV14ASSY	SBV14ASSY
I	Salt Platform	BTSG12	BTSG12	BTSG18	BTSG18	BTSG18	BTSG18	BTSG18
J**	Bypass Valve Less Fittings	CV3006	CV3006	CV3006	CV3006	CV3006	CV3006	CV3006
K	Elbow Locking Clip	FC103	FC103	FC103	FC103	FC103	FC103	FC103

*A top screen (CD1203, not shown) is included with the control valve assembly of IIX and HEX series units

**Refer to "Installation Fitting Assemblies" pages 19-21 for available I/O fittings.

ALL MODELS INCLUDE ¾ QUICK CONNECT FITTINGS AS WELL AS 1" MALE NPT ELBOWS

Control Valve Breakdown

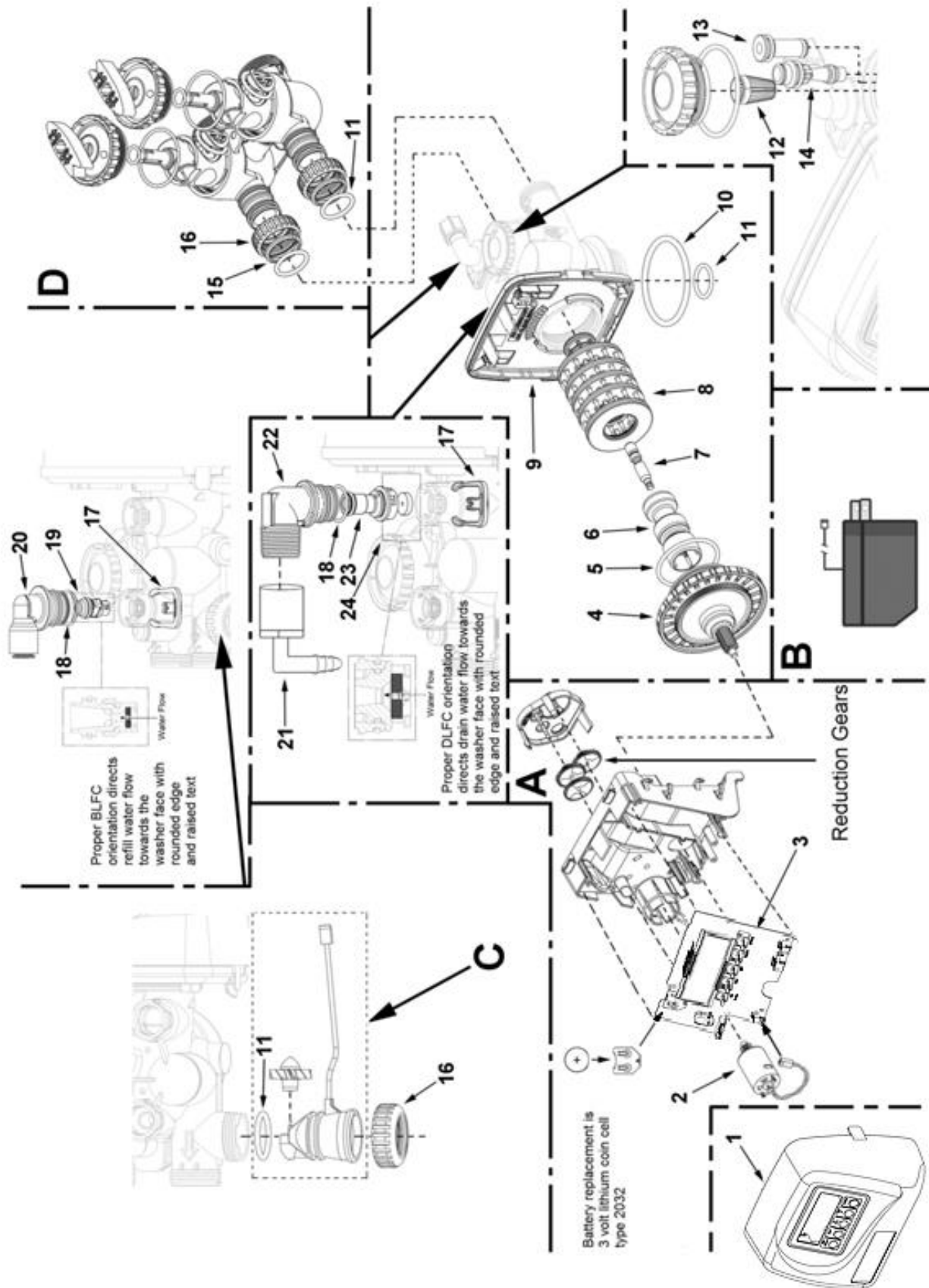

Control Valve Parts List

REF #	Part Number	Description
A	CV3002	Drive Assembly, IX Series
B	CV3186	Power Cord with Transformer
C	CV3003	Meter and Cable Assembly
D	CV3006	Bypass Valve, Less Fittings
1	CV3175-01	Front Cover, Black, IX Series
2	CV3107-01	Drive Motor
3	CV3108-11BOARD	Circuit Board, IX Series
4	CV3004	Drive Cap Assembly
5	CV3135	O-ring, -228
6	CV3011	Piston Assembly
7	CV3174	Brine Valve
8	CV3005	Seal Cartridge Assembly
9	CV3178	Back Plate
10	CV3180	Base O-ring, -337
11	CV3105	O-ring, -215
12	CV3177-01	Injector Screen
13	CV3010-1Z	Plug, Injector Assembly
14	CV3010-1F	Injector, Blue
15	CV3150	Retainer, Split Ring
16	CV3151	Nut, 1" Quick Connect
17	CH4615	Clip, Elbow Locking
18	CV3163	O-ring, -019
19	CV3165-01	Retainer, Brine Refill Flow Control
20	CV4144	3/8" Elbow, Parker fitting
21	GL463412	Elbow, Drain Line, 1/2" Barbed x 3/4" Female
22	CV3158-02	Elbow, Drain, 3/4" Male
23	CV3159-01	Retainer, Drain Line Flow Control
24	CV3162-017 CV3162-027 CV3162-032 CV3162-042 CV3162-053	Drain Line Flow Control Button: Flow Control Washer, 1.7 GPM (for IX0844-1, HEX0844-1) Flow Control Washer, 2.7 GPM (for ICX0835-1, IX0948-1, IIX0948-1, HECX0935-1 and HEX0948-1) Flow Control Washer, 3.2 GPM (for INTX1035-1, ICX1035-1, IX1054-1, HECX1035-1, HEX1054-1) Flow Control Washer, 4.2 GPM (for IX1248-1, IIX1248-1, HEX1248-1) Flow Control Washer, 5.3 GPM (for IX1354-1, and HEX1354-1)

Installation Fitting Assemblies

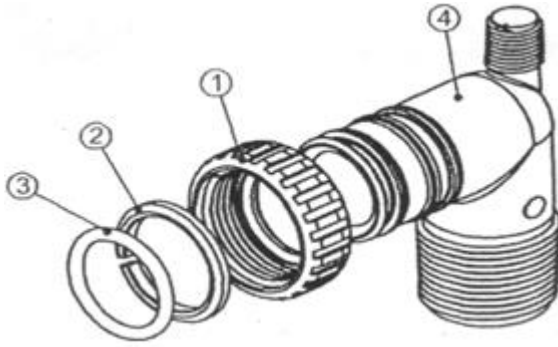

1" PVC MALE NPT ELBOW			
Ref	Part #	Description	Qty
	CV3007	1" PVC male NPT elbow assy	2
1	CV3151	Nut, 1" quick connect	2
2	CV3150	Split ring	2
3	CV3105	O-ring 215	2
4	CV3149	Fitting	2

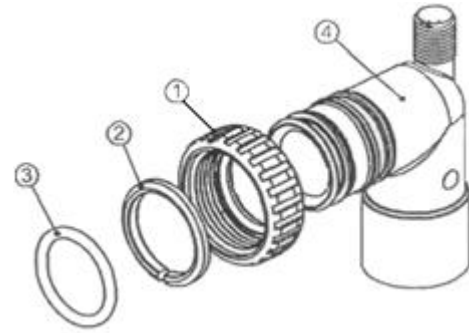

3/4" & 1" PVC SOLVENT ELBOW			
Ref	Part #	Description	Qty
	CV3007-01	3/4" & 1" PVC solvent elbow assy	2
1	CV3151	Nut, 1" quick connect	2
2	CV3150	Split ring	2
3	CV3105	O-ring 215	2
4	CV3189	Fitting	2

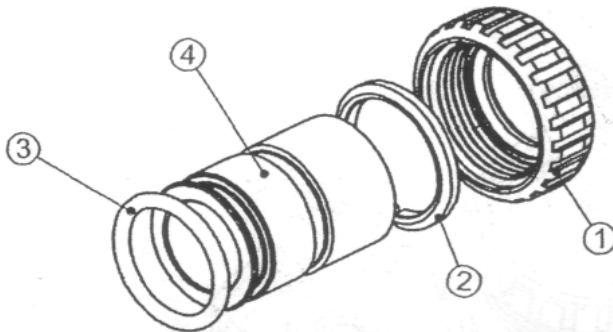

1" BRASS SWEAT			
Ref	Part #	Description	Qty
	CV3007-02	1" brass sweat assembly	2
1	CV3151	Nut, 1" quick connect	2
2	CV3150	Split ring	2
3	CV3105	O-ring 215	2
4	CV3188	Fitting	2

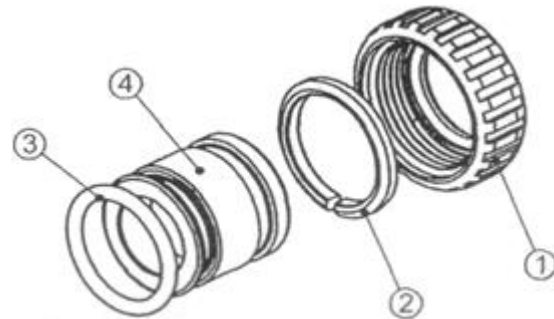

3/4" BRASS SWEAT			
Ref	Part #	Description	Qty
	CV3007-03	3/4" brass sweat assembly	2
1	CV3151	Nut, 1" quick connect	2
2	CV3150	Split ring	2
3	CV3105	O-ring 215	2
4	CV3188-01	Fitting	2

Installation Fitting Assemblies (cont.)

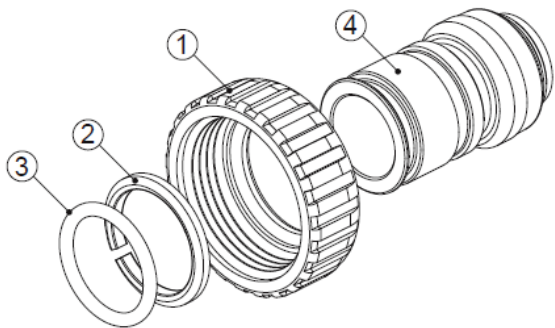

3/4" BRASS SHARK BITE			
Ref	Part #	Description	Qty
	CV3007-12	3/4" brass shark bite assembly	2
1	CV3151	Nut, 1" quick connect	2
2	CV3150	Split ring	2
3	CV3105	O-ring 215	2
4	CV3628	Fitting	2

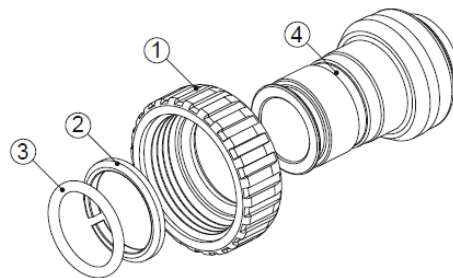

1" BRASS SHARK BITE			
Ref	Part #	Description	Qty
	CV3007-13	1" brass shark bite assembly	2
1	CV3151	Nut, 1" quick connect	2
2	CV3150	Split ring	2
3	CV3105	O-ring 215	2
4	CV3629	Fitting	2

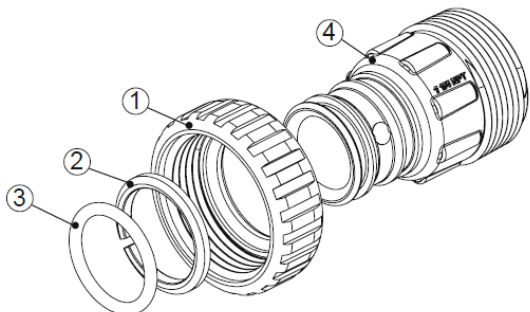

1-1/4" PLASTIC MALE NPT			
Ref	Part #	Description	Qty
	CV3007-05	1-1/4" plastic male NPT assembly	2
1	CV3151	Nut, 1" quick connect	2
2	CV3150	Split ring	2
3	CV3105	O-ring 215	2
4	CV3317	Fitting	2

Installation Fitting Assemblies (cont.)

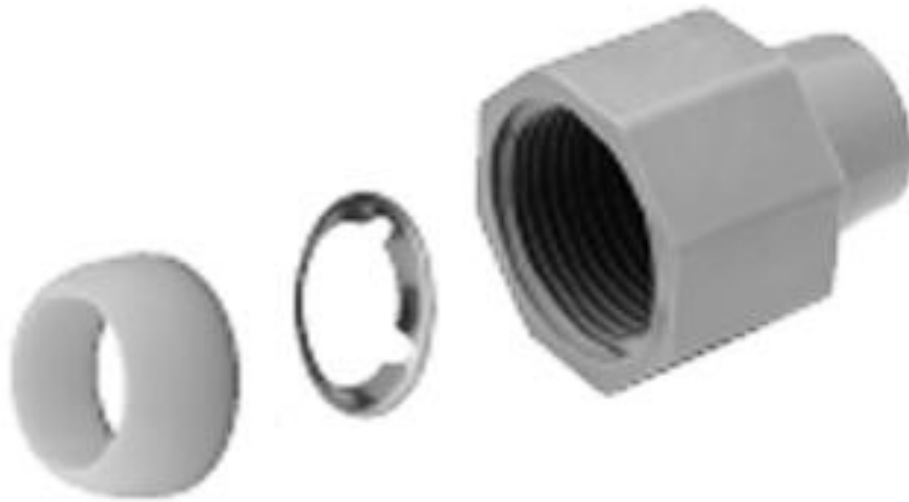

3/4" QUICK CONNECT			
Ref	Part #	Description	Qty
K	QFNCR4	3/4" QUICK CONNECT	1*

(*2 required)

SERVICE WRENCH - CV3193

Although no tools are necessary to assemble or disassemble the valve, the *Service Wrench*, (shown in various positions on the valve) is available to aid in assembly or disassembly.

Loosens Drain Nut In
Polytube Applications

Loosens Injector and
Bypass Caps

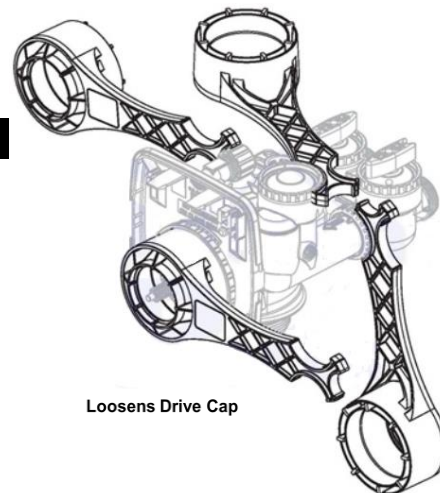

Loosens Quick
Connect Nuts

Loosens Drive Cap

Troubleshooting

PROBLEM	CAUSES	SOLUTIONS
Brine tank overfills or does not draw brine	<ul style="list-style-type: none"> A) Loose nut at either end of the brine line B) Brine line inserted into the brine tank overflow fitting rather than connected to the safety brine valve C) Softener drain line connected to brine overflow fitting or overflow drain line D) Obstruction in the control valve E) Problems with drain line: plugged, frozen, kinked, flexible tubing, overhead installation, diameter too small, longer than 15' F) Missing BLFC G) Missing brine stem H) Dirty brine tank 	<ul style="list-style-type: none"> 1) Tighten nuts at either end of brine line 2) Verify brine line is installed correctly 3) Verify softener drain line is not connected to brine overflow elbow or brine overflow drain line 4) Check for debris in DLFC Assembly, BLFC Assembly, injector, injector screen 5) Manually put softener into Backwash Cycle (page 9, beginning with step 11) and unplug the transformer for 30 minutes to dislodge debris from inside the control valve or disassemble and clean control valve internal components 6) Resolve issues with the drain line 7) Verify brine line flow control button is not missing 8) Verify piston brine stem is not missing 9) Clean out brine tank
Hard water or softener not using salt	<ul style="list-style-type: none"> A) Softener is plugged into an electrical outlet without power or one that is tied to a switch B) No salt in the brine tank C) Salt in the brine tank has "bridged" D) Bypass Valve is not in "Service" position or is leaking E) Obstruction in control valve I) Problems with drain line: : (See letter "E" in prior section) F) Control valve programmed incorrectly G) Softener sized improperly for actual service flow rates H) Faulty or unplugged drive motor I) Meter cable disconnected 	<ul style="list-style-type: none"> 1) Verify softener has uninterrupted power 2) Fill brine tank with salt 3) Hit the side of the brine tank with rubber mallet to break any bridging that has formed in the brine tank 4) Verify bypass is in "Service" position (Figure 2, Page 4) 5) Check for debris in DLFC Assembly, BLFC Assembly, injector, injector screen 6) Manually put softener into Backwash Cycle (page 9, beginning with step 11) and unplug transformer for 20-30 minutes to dislodge debris 7) Resolve issues with drain line 8) Review control valve programming 9) Verify actual service flow rates required and compare to system specifications (pages 13-14) 10) Verify drive motor is connected to control valve circuit board connector J1 (labeled "MOTOR") 11) Verify meter cable (grey cable, 3 pins) is connected to control valve circuit board connector J2 (labeled "METER")

Troubleshooting (cont.)

PROBLEM	CAUSES	SOLUTIONS
Softener regenerates at wrong time of day	<ul style="list-style-type: none"> A) Clock is not set B) Power outage C) Incorrect control valve programming 	<ul style="list-style-type: none"> 1) Reset softener clock (page 7) 2) Verify control valve programming (page 8)
Resin in water lines, plugged aerators	<ul style="list-style-type: none"> A) Unit is installed backwards B) Distributor basket is damaged 	<ul style="list-style-type: none"> 1) Re-plumb unit with water supply entering bypass inlet (page 5) 2) Replace damaged distributor basket
Salty Water	<ul style="list-style-type: none"> A) Brine tank overfilled B) Problems with drain line: (See Letter "E" in Brine Tank Overfill section) C) Rinse cycle is short D) Salt setting too high E) Distributor tube improperly seated in control valve or is too short F) Low water pressure 	<ul style="list-style-type: none"> 1) See "Brine tank overfills" section (Page 22) 2) Resolve drain line issues 3) Contact technical support for assistance in verifying \ adjusting Rinse Cycle length and Salt Setting 4) Verify proper installation of distributor tube 5) Verify at least 25 psi of line pressure
Softener leaks to drain in "Service" position	<ul style="list-style-type: none"> A) Problem in piston cartridge assembly B) Control valve is jammed or halted during regeneration C) Drive cap assembly is not tightened properly 	<ul style="list-style-type: none"> 1) Replace seals and/or piston if needed 2) Verify control valve is in "SOFTENING" mode 3) Tighten drive cap assembly
Low water pressure	<ul style="list-style-type: none"> A) Iron or sediment build up in softener B) Insufficient pump capacity 	<ul style="list-style-type: none"> 1) Increase backwash frequency by increasing hardness setting (page 8) 2) Verify at least 25 psi of line pressure
Display is blank	<ul style="list-style-type: none"> A) Control valve circuit board needs reset B) Transformer is unpowered, unplugged or defective C) Defective circuit board 	<ul style="list-style-type: none"> 1) Hold "NEXT" and "REGEN" buttons for 3 seconds 2) Remove battery, unplug power for 5 seconds, plug back in, replace dead battery 3) Verify transformer is plugged into an electrical outlet that has power and transformer cable (black, 4 pins) is plugged into control valve connector J4 (labeled "POWER") 4) With transformer plugged into electrical outlet, use a volt meter to test the 2 outer pins (furthest left and furthest right) of connector J4 on the control valve circuit board. Should be approximately 15 volts DC. Replace transformer if defective. 5) Replace circuit board if needed
"SOFTENING" does not display when water is flowing	<ul style="list-style-type: none"> A) Bypass valve not in "Service" position B) Meter cable disconnected C) Restricted/stalled meter turbine D) Defective meter 	<ul style="list-style-type: none"> 1) Verify bypass is in "Service" position (Figure 2, Page 4) 2) Verify meter cable (grey cable, 3 pins) is connected to control valve circuit board connector J2 (labeled "METER") 3) Remove meter and check for restriction 4) Replace meter if needed

Troubleshooting (cont.)

PROBLEM	CAUSES	SOLUTIONS
Display shows incorrect time-of-day or time-of-day flashes	<ul style="list-style-type: none"> A) Outlet is on a switch B) Power outage C) Control valve was reset D) Defective circuit board 	<ul style="list-style-type: none"> 1) Use an un-switched outlet 2) Reset time-of-day 3) Replace circuit board if needed
ERROR CODE:		
1001 – unable to sense motor movement	<ul style="list-style-type: none"> A) Drive motor not inserted fully to engage pinion or is defective B) Circuit board not properly snapped into drive bracket C) Center reduction gear reflector dirty 	<ul style="list-style-type: none"> 1) Re-insert motor, check for broken wires, verify motor plugged into connector J1 (labeled “MOTOR”) on control valve circuit board and reset control valve (hold “NEXT” and “REGEN” buttons for 3 seconds) 2) Re-seat circuit board into drive bracket and reset control valve 3) Clean reduction gear reflectors (page 19)
1002 – unexpected motor stall	<ul style="list-style-type: none"> A) Obstruction in control valve B) Main drive gear too tight C) Improper voltage delivered to circuit board 	<ul style="list-style-type: none"> 1) Remove piston and seal assemblies for inspection and repair or replacement and reset control valve (hold “NEXT” and “REGEN” buttons for 3 seconds) 2) Loosen main drive gear and reset control valve 3) Verify proper voltage is being supplied to circuit board (see Solution 4 under “Display is Blank” section, page 23)
1003 – motor ran too long, cannot find next cycle position	<ul style="list-style-type: none"> A) Motor failure during regeneration B) Obstruction in control valve C) Drive bracket not snapped in place properly 	<ul style="list-style-type: none"> 1) Re-insert motor, check for broken wires, verify motor plugged into connector J1 (labeled “MOTOR”) on control valve circuit board and reset control valve (hold “NEXT” and “REGEN” buttons for 3 seconds) 2) Remove piston and seal assemblies for inspection and repair or replacement and reset control valve 3) Re-seat drive bracket assembly and reset control valve
1004 – motor ran too long, timed out trying to reach home position	<ul style="list-style-type: none"> A) Drive bracket not snapped in place properly B) Center reduction gear reflector dirty 	<ul style="list-style-type: none"> 1) Re-seat drive bracket assembly and reset control valve (hold “NEXT” and “REGEN” buttons for 3 seconds) 2) Clean reduction gear reflectors (page 17)
1006 – MAV/SEPS/NHBP/AUX MAV motor ran too long, looking for park position	<ul style="list-style-type: none"> A) Control valve not programmed for ALT OFF B) Obstruction in control valve 	<ul style="list-style-type: none"> 1) Enter cycle programming level and verify second parameter is set to ALT OFF 2) Remove piston and seal assemblies for inspection and repair or replacement and reset control valve (hold “NEXT” and “REGEN” buttons for 3 seconds)
1007 – MAV/SEPS/NHBP/AUX MAV motor ran too short looking for park position	<ul style="list-style-type: none"> A) Control valve not programmed for ALT OFF B) Obstruction in control valve 	<ul style="list-style-type: none"> 1) Enter cycle programming level and verify second parameter is set to ALT OFF 2) Remove piston and seal assemblies for inspection and repair or replacement and reset control valve (hold “NEXT” and “REGEN” buttons for 3 seconds)

TEN YEAR LIMITED WARRANTY

WARRANTY – First Sales warrants this water conditioner against any defects that are due to faulty material or workmanship during the warranty period. This warranty does not include damage to the product resulting from accident, neglect, misuse, misapplication, alteration, installation or operation contrary to printed instructions, or damage caused by freezing, fire, flood, or Acts of God. From the original date of consumer purchase, we will repair or replace, at our discretion, any part found to be defective within the warranty period described below. Purchaser is responsible for any shipping cost to our facility and any local labor charges.

- One year on the entire water conditioner
- Five years on the control valve
- Ten years on the mineral tank

GENERAL CONDITIONS – Should a defect or malfunction occur, contact the dealer that you purchased the product from. If you are unable to contact the dealer, contact First Sales, LLC. @ (260)693-1972. We will require a full description of the problem, model number, date of purchase, and selling dealer’s business name and address.

We assume no warranty liability in connection with this water conditioner other than specified herein. This warranty is in lieu of all other warranties, expressed or implied, including warranties of fitness for a particular purpose. We do not authorize any person or representative to assume for us any other obligations on the sale of this water conditioner.

FILL IN AND KEEP FOR YOUR RECORDS

Original Purchaser	Date of Purchase	Model #	
Address of Original Installation		City	State
Dealer Purchased From	Dealer Address	City	State

**First Sales
12630 U.S. 33 North, Churubusco, IN 46723
Phone: (260)693-1972 Fax: (260)693-0602**