

# Installation Instructions and Owner's Manual

## PIF1 Series

### Backwashing Air Injection Iron Filter System



---

---

#### Franklin Water Treatment, LLC

12630 US Highway 33 N  
Churubusco, IN 46723

Phone (260) 693-1972 Fax (260) 693-0602

# Table of Contents

<b>Pre-installation Instructions</b>	<b>Page 2</b>
<b>Media Types</b>	<b>Page 2</b>
<b>General Installation</b>	<b>Page 4</b>
<b>Bypass Valve</b>	<b>Page 5</b>
<b>Installation Instructions</b>	<b>Page 6</b>
<b>General Operation</b>	<b>Page 10</b>
<b>Maintenance</b>	<b>Page 11</b>
<b>Troubleshooting Guide</b>	<b>Page 13</b>
<b>Specifications</b>	<b>Page 16</b>
<b>Component Parts Breakdown</b>	<b>Page 17</b>
<b>Component Parts List</b>	<b>Page 18</b>
<b>Control Valve Breakdown</b>	<b>Page 19</b>
<b>Control Valve Parts List</b>	<b>Page 20</b>
<b>Installation Fittings</b>	<b>Page 21</b>
<b>Ten Year Limited Warranty</b>	<b>Page 24</b>

# Pre-installation Instructions

## Description of the filter system:

The PIF1 system includes a filtration tank (with gravel and distributor) and a backwashing control air draw control valve with bypass valve and plumbing adapters. Filtration media used with the PIF1 system may be of the following types:

PART NUMBER	MEDIA TYPE / APPLICATION	VOLUME (CU. FT.)	PACKAGE	SHIP. WT. (LBS.)
A10	ACTIVATED CARBON TASTE & ODOR REDUCTION	1.00	BAG	29
A05P		0.50	PAIL	14
ACC10	CATALYTIC CARBON TASTE & ODOR REDUCTION	1.00	BAG	29
ACC05P		0.50	PAIL	14
C05P	CALCITE SELF LIMITING ACID NEUTRALIZER	0.50	PAIL	45
FA10	FILTER – AG SUSPENDED SOLIDS REDUCTION	1.00	BAG	24
FA05P		0.50	PAIL	12
IP05	IRON PRO IRON REDUCTION & PH ELEVATION	0.50	PAIL	49
IP05M	IRON PRO M-BED IRON REDUCTION & EXTRA PH ELEVATION	0.50	PAIL	47
K10	KATALOXLIGHT SULFUR & IRON REDUCTION PH ELEVATION (Higher BW flow rate required!)	1.00	BAG	65
K05P		0.50	PAIL	35
QFS05P	QUARTZ FILTER SAND (.45mm x .55mm) SEDIMENT REDUCTION (Higher BW flow rate required!)	0.50	PAIL	51
Z05P	ZEOLITE SUSPENDED SOLIDS & SEDIMENT REDUCTION (Higher BW flow rate required!)	0.50	PAIL	25
A8042	GREENSAND PLUS CATALYTIC MEDIA FOR OXIDATION APPLICATIONS (Higher BW flow rate required!)	0.50	BAG	44

## Successful Application

Any filter media may have specific limitations and/or requirements for successful application. Consult with technical services when selecting filter media for this system and the specific application.

## Time of Regeneration

Periodically the control valve will go through a backwash cycle. This cycle is factory preset to 1:00 A.M. flushing the accumulated sediment and/or precipitant to the drain. After the backwashing process the unit is now prepared for the next period of service.

# Pre-installation Instructions (cont.)

## Water Supply

This filter will function properly when the water supply is furnished by a jet pump, submersible pump, variable speed (constant pressure) pump or community water supply. As with all other filter systems, however, it is imperative that the well pump provides enough flow rate for the filter to adequately backwash. To ensure sufficient backwash flow rate, the following pumping rate test should be performed prior to installing the PIF1. Backwash flow rate required may vary from the installed DLFC depending on the media used with the filter.

1. Make certain no water is being drawn in the house.
2. Open spigot nearest pressure tank.
3. When well pump starts, close spigot and measure time (in seconds) to refill pressure tank (well pump turns back off). This is **Cycle Time**.
4. Using a container of known volume, draw water from pressure tank and measure how many gallons until the pump turns back on again. This is **Draw Down**.
5. Calculate pumping rate by dividing draw down by cycle time and multiplying by 60.

$$\frac{\text{Draw Down (gallons)}}{\text{Cycle Time (seconds)}} \times 60 = \text{Pumping Rate (gallons per minute)}$$

Example: Draw down is 8 gallons  
Cycle time is 65 seconds

$$\frac{8 \text{ gallons}}{65 \text{ seconds}} \times 60 = 7.4 \text{ gpm (gallons per minute)}$$

## Location Considerations

The proper location to install the PIF1 will ensure optimum filter performance and satisfactory water quality. The following factors should be considered in selecting the location of this system.

1. The PIF1 must be installed after the pressure tank (private well system only).
2. The system should be installed as close as possible (preferably within 15') to an adequate floor or laundry drain capable of handling the backwash cycle volume and flow rate (refer to unit specifications). An air gap should be provided between the PIF1 drain line and plumbing drain.
3. All water conditioning equipment should be installed at least 10' prior to the water heater. Water temperatures exceeding 100°F can damage the internal components of the control valve and filter tank. An expansion tank may need to be installed in the line to the water heater to allow for thermal expansion and comply with local plumbing codes.
4. Water pressure must not exceed the range of 25 - 100 psi.
5. The system must not be subject to freezing temperatures.
6. The control valve requires 115/120 V, 60 Hz electricity from an outlet that is not wired to a switch.
7. Never install a cartridge type filter prior to the PIF1. Any cartridge or in-line filter (if desired) may be installed after the PIF1 system. This will prevent restricting the water flow and pressure available for backwash.
8. Appliances requiring extended periods of continuous or high flow water use (i.e. geothermal heat pumps, swimming pools, lawn irrigation, outside hose bibs, etc.) should bypass the filter.

# General Installation

## GENERAL INSTALLATION & SERVICE WARNINGS

The water conditioner is not designed to support the weight of plumbing.

Do not use Vaseline, oils, other hydrocarbon lubricants or spray silicone anywhere. A silicone lubricant may be used on black "O" Rings. This will allow ease of installation and decrease chance of rolling from the bypass and tank connections. *Avoid any type of lubricants, including silicone, on red or clear lip seals.*

Do not use pipe dope or other sealants on threads. Teflon® tape may be used as required. Teflon® tape is not used on any connection where "O" Ring seals are used

The nuts and caps are designed to be unscrewed or tightened by hand or with the special plastic Service Wrench, (CV3193, not included). If necessary, pliers can be used to unscrew the nut or cap. Do not use a pipe wrench to tighten nuts or caps. *Do not place screwdriver in slots on caps and/or tap with a hammer.*

NOTE: If the plumbing system is used as the ground leg of the electric supply, continuity should be maintained by installing ground straps around any non-conductive plastic piping or bypass used in the installation.

Make sure the filter is not installed backwards. The filter will not function properly if installed backwards and filter media may be forced into the service lines. Arrows molded into the valve body and red handles of the bypass indicate the direction of flow.

The PIF1 has a check valve (OV32) installed in the inlet of the control valve. This check valve will prevent hot water expansion in the plumbing. **An expansion tank must be used on the water heater supply line to allow for thermal expansion.**

All local plumbing codes must be followed.

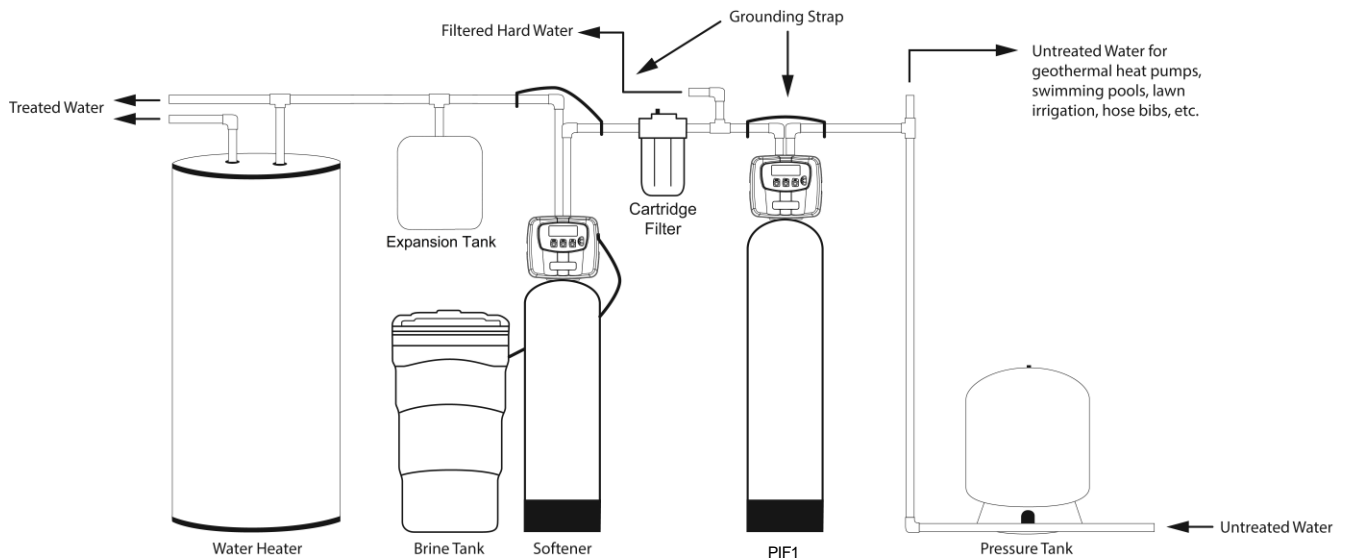

**FIGURE 1: Typical Installation**

# Bypass Valve

The bypass valve is used to isolate the control valve from the plumbing system's water pressure in order to perform control valve repairs or maintenance. The 1" full flow bypass valve incorporates four positions including a diagnostic position that allows a service technician to have pressure to test a system while providing untreated bypass water to the building. Be sure to install bypass valve onto main control valve, before beginning plumbing or make provisions in the plumbing system for a bypass. The bypass body and rotors are glass filled Noryl® and the nuts and caps are glass filled polypropylene. All seals are self-lubricating EPDM to help prevent valve seizing after long periods of non-use. Internal "O" Rings can easily be replaced if service is required. The bypass consists of two interchangeable plug valves that are operated independently by red arrow shaped handles. The handles identify the direction of flow. The plug valves enable the bypass valve to operate in four positions.

1. **Normal Operation Position:** The inlet and outlet handles point in the direction of flow indicated by the engraved arrows on the control valve. Water flows through the control valve for normal operation of a water softener or filter. During the regeneration cycle this position provides regeneration water to the unit, while also providing untreated water to the distribution system (**Fig. 2**).
2. **Bypass Position:** The inlet and outlet handles point to the center of the bypass. The system is isolated from the water pressure in the plumbing system. Untreated water is supplied to the building (**Fig. 3**).
3. **Diagnostic Position:** The inlet handle points toward the control valve and the outlet handle points to the center of bypass valve. Untreated supply water is allowed to flow to the system and to the building, while not allowing water to exit from the system to the building (**Fig. 4**). This allows the service technician to draw brine and perform other tests without the test water going to the building.

**NOTE:** The system must be run through a rinse cycle before returning the bypass valve to the normal position.

4. **Shut Off Position:** The inlet handle points to the center of the bypass valve and the outlet handle points away from the control valve. The water is shut off to the building. The water treatment system will depressurize upon opening a tap in the building. A negative pressure in the building combined with the softener being in regeneration could cause a siphoning of brine into the building. If water is available on the outlet side of the softener it is an indication of water bypassing the system (**Fig. 5**)

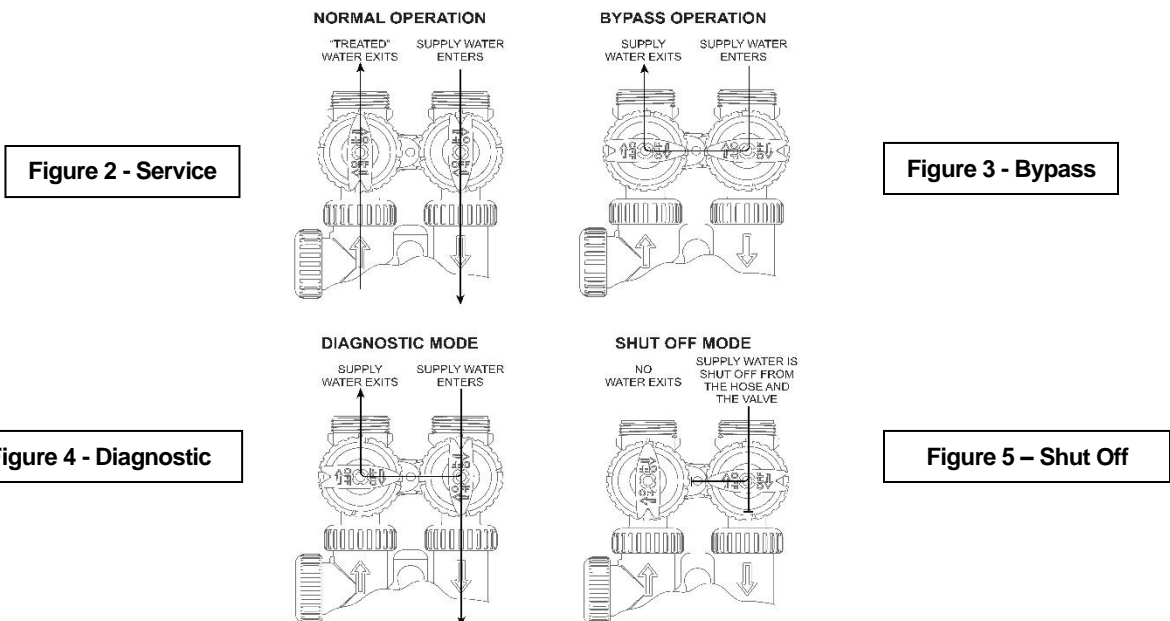

# Installation Instructions

- STEP 1:**      **Unpack filter unit**, making sure to remove entire contents of the shipping container prior to disposal.
- STEP 2:**      With the filter unit in the upright position, **remove the control valve** from the mineral tank being careful to not pull the distributor out of the gravel at the bottom of the tank. **If the filter model has a “-DH” suffix, do not remove the control valve. Just remove the tank dome hole plug.**
- STEP 3:**      If the control valve was removed, cover the top of the distributor tube with the included red cap. Using the included blue media funnel, **pour filter media(s) into the mineral tank**. If using multiple filter media types, load in the order of heaviest (most dense) to lightest (least dense). 14” of space **MUST** be left empty at the top of the mineral tank to allow for media bed expansion during backwash and to prevent filter media from being discharged through the drain line.
- STEP 4:**      Use a garden hose or bucket to **fill the media tank with water**.  
**IMPORTANT: Carbon, Filter Ag, Zeolite and Greensand Plus must be soaked for at least 2 hours prior to submitting it to full backwash flow rate to prevent loss of media to drain.**
- STEP 5:**      Clean mineral tank threads to remove any filter media. If the control valve was removed, remove red cap from distributor tube and **reinstall control valve** by threading it securely onto the mineral tank. Otherwise simply replace the tank dome hole plug. (O-ring seal: **HAND TIGHTEN ONLY!**)
- STEP 6:**      **Shut off all water at main supply**. On private well system, turn off power to pump and drain pressure tank. Make certain pressure is relieved from complete system by opening nearest faucet to drain system. **SHUT OFF FUEL / ELECTRICAL SUPPLY TO WATER HEATER.**
- STEP 7:**      **Plumb the water supply line** to the unit's bypass valve inlet, located at the right rear as you face the unit. There are a variety of installation fittings available. They are listed under Installation Fitting Assemblies, pages 23-25. When assembling the installation fitting package (inlet and outlet), connect the fitting to the plumbing system first and then attach the nut, split ring, and "O" Ring. Heat from soldering or solvent cements may damage the nut, split ring, or "O" Ring. Solder joints should be cool and solvent cements should be set before installing the nut, split ring, and "O" Ring. Avoid getting solder flux, primer, and solvent cement on any part of the "O" Rings, split rings, bypass valve, or control valve. If the building's electrical system is grounded to the plumbing, install a copper grounding strap from the inlet to the outlet pipe. Plumbing must be done in accordance with all applicable local codes. **MAKE CERTAIN WATER ENTERS THROUGH INLET AND DISCHARGES THROUGH OUTLET.**
- STEP 8:**      **Apply thread tape to DLFC Assembly**. Remove drain line flow control (DLFC) retainer clip (Figure 6, Page 7) and remove the DLFC assembly from the valve body, (Figure 6, Page 7). Apply thread tape to threads. Slide drain fitting compression nut onto provided drain tubing and place the tube insert inside the end of the tubing. Insert tubing end with insert into drain elbow and tighten the compression nut onto the thread taped elbow. Reinsert DLFC assembly into the valve body, making certain it is **FULLY** inserted before replacing the retaining clip.
- STEP 9:**      **Install drain line**. Use the provided ½” I.D. polyethylene tubing (**DO NOT USE FLEXIBLE VINYL TUBING!**) to run drain line from control valve DLFC fitting (Figure 6, Page 7) to floor drain or sump pit capable of handling the backwash rate of the filter (refer to specifications and flow rate on page 17) or discard the compression fitting and use the ¾” NPT fitting to connect a rigid pipe drain line . If backwash flow rate is greater than 7.5 gpm, use existing NPT connector with rigid drain line. There must be an air gap at the end of the drain line to prevent siphoning of wastewater. Length of drain line should be 15' or less. **AVOID OVERHEAD DRAINS.**

## Installation Instructions (cont.)

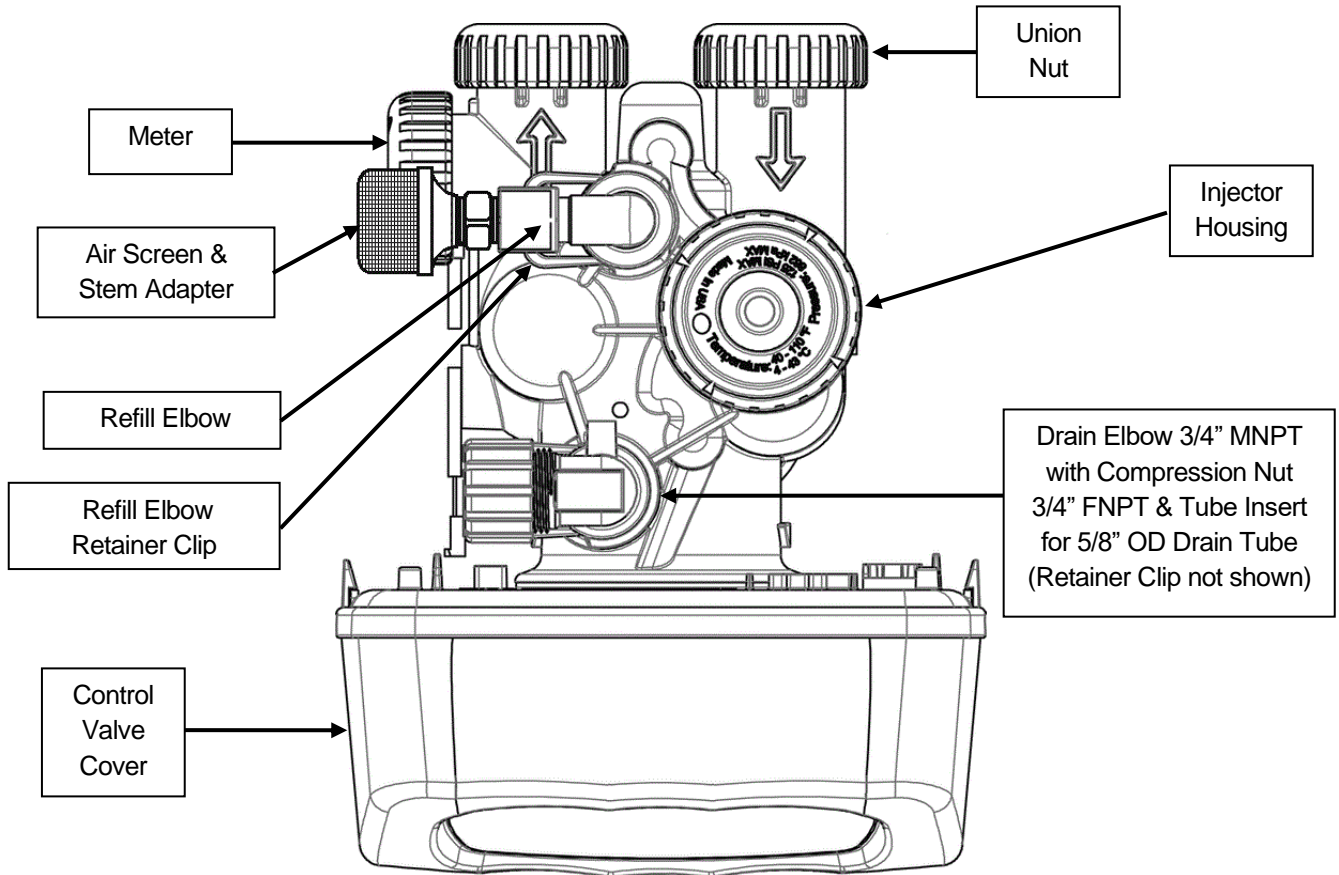

**FIGURE 6: Top View of Control Valve**

**STEP 10:** With the bypass valve handles in the bypass position (Figure 3, Page 5), turn on water supply. Turn the inlet bypass valve handle to the diagnostic position (Figure 4, Page 5) and allow the filter to pressurize. NOTE: the INLET and OUTLET knobs turn *clockwise* to close the port to the filter and *counter-clockwise* to open the port to the filter. Check for leaks and correct as needed. Return the inlet bypass valve handle to the bypass position.

**STEP 11:** **Program control valve.** Plug the transformer of the control valve into an uninterrupted electrical outlet (not wired to a switch) and use the buttons on the front of the control valve to adjust the initial settings.

### A) SET THE TIME OF DAY

1. Press the "CLOCK" button
  - a. The upper left of the display will show "TIME SET HOUR"
  - b. The hour will flash
2. Press the "UP" or "DOWN" buttons (triangle pointing up or down) until the correct combination of hour and "AM" or "P M" is reached to match the current time.
3. Press the "NEXT" button
  - a. The upper left of the display will show "TIME SET MINUTES"
  - b. The minutes will flash



## Installation Instructions (cont.)

4. Press the “UP” or “DOWN” buttons until the minutes match the current time.
5. Press the “NEXT” button to return to the main display

**B) Enter Programming:** Press “NEXT” and “UP” (triangle pointing up) buttons simultaneously for 3 seconds.

1. **Days Between Regeneration:**
  - a. The upper left of the display will show “DAYS BETWEEN REGEN SET”
  - b. A number will flash (default 3)
2. Using the “UP” or “DOWN” (triangle pointing up or down) buttons, set the number of days (default 3) between regenerations. **NOTE: more frequent regeneration may be required depending on the quality of the water.**
3. **Regeneration Time:** Press the “NEXT” button
  - a. The upper left of the display will show “REGEN TIME HOUR SET”
  - b. The hour will flash
4. **Regeneration Hour:** Using the “UP” or “DOWN” buttons, set the combination of hour of day and “AM” or “PM”. Make sure the filter is not regenerating at the same time with any other water treatment equipment.
5. Press the “NEXT” button
  - a. The upper left of the display will show “REGEN TIME MINUTES SET”
  - b. The minutes will flash
6. **Regeneration Minutes:** Using the “UP” or “DOWN” buttons, set the minutes portion of the time when regeneration should occur.
7. **Exit Programming:** Press the “NEXT” button to return to the main display

**STEP 12:** **Initiate Manual Regeneration (Backwash Cycle):** With the bypass valve in the bypass position, press and hold the “REGEN” button 3 seconds or until the word “BACKWASH” appears in the upper left of the display. The drive motor will run briefly, and a count-down timer will appear in the lower right the display. There will be an audible release of pressure to the drain.

**IMPORTANT: Carbon, Filter Ag, Zeolite and Greensand Plus must be soaked for at least 2 hours prior to submitting it to full backwash flow rate to prevent loss of media to drain.**

**STEP 13:** **Unplug the transformer from the electrical outlet** to keep the PIF1 in backwash for an extended time to purge any air and remove media “fines” (very small particles of media).

**STEP 14:** Slowly turn the INLET knob of the bypass, counterclockwise, to a point approximately 1/3 of the way between “Bypass” and “Service” positions (Figure 2, Page 5) or until the remaining air is released from the tank.

**STEP 15:** Once the air is purged, gradually turn the INLET knob of the bypass valve counterclockwise until it is fully in “Service” position (Figure 2, Page 5). Then turn the OUTLET knob of the bypass valve counterclockwise until it is fully in the “Service” position (Figure 2, Page 5). and **leave the control valve in “Backwash” position for at least 10 minutes or until water flowing from the drain line runs clear; whichever is longer.**

## Installation Instructions (cont.)

- STEP 16:**      **Regenerant Draw Cycle:** Plug the transformer into the electrical outlet. Press the “REGEN” button to advance the control valve to the “REGENERANT DRAW DN” cycle. Another count-down timer will appear in the time-of-day position, “REGENERANT DRAW DN” will be shown in the upper part the display.
- STEP 17:**      **Complete Manual Regeneration:** Allow the regeneration to complete and the filter will return to service mode automatically.
- STEP 18:**      **TURN ON FUEL / ELECTRICAL SUPPLY TO WATER HEATER.**

**RECOMMENDED:** Retain the red distributor cap and blue media funnel for future replenishment of filter media.

**NOTE:** If the PIF1 filter is loaded with any self-sacrificing media like Calcite or Iron Pro and the pH is less than 7, mark the media level on the side of the tank by shining a bright light through the tank to see its level. Replenish the media in the mineral tank when the level drops by more than three inches.

# General Operation

## USER DISPLAYS

When the system is operating, one of several displays may be shown. Pressing NEXT will alternate between the displays. One of the displays is the current time of day. The second display shows days to a regen/gallons remaining (depending on how it is programmed). Days To A Regen is the number of days left before the system goes through a regeneration cycle. Capacity remaining is the number of gallons that will be treated before the system goes through a regeneration cycle. The third display is current flow in gal/min. The user can scroll between the displays as desired by pushing NEXT or display will scroll automatically. When water is being treated (i.e. water is flowing through the system) the word "GPM" flashes on left side of display when other than flow rate is displayed. User screens will continuously scroll, switching views every 3 seconds. If the screens are manually scrolled, this screen will remain constant for 5 minutes then continue to scroll. The conditional screens will take precedence over the scrolling and the conditional conditions will apply. To manually reduce capacity, press down button while capacity remaining or days to a regen is displayed.

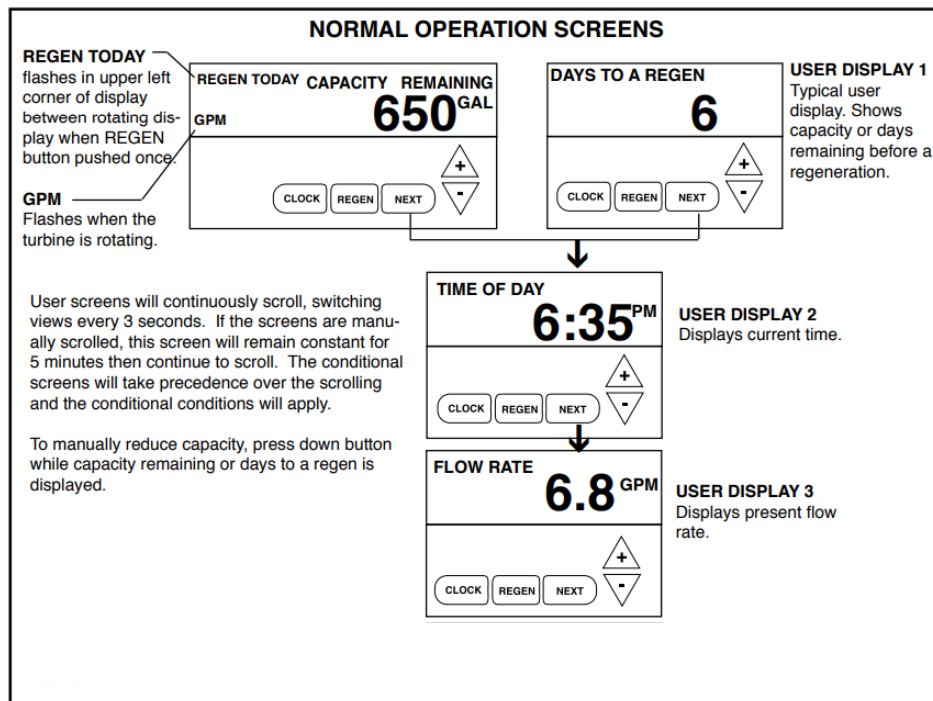

## MANUAL REGENERATION

Sometimes there is a need to regenerate the system sooner than when the system calls for it, usually referred to as manual regeneration. There may be a period of heavy water usage because of guests or a heavy laundry day. To initiate a manual regeneration at the preset delayed regeneration time, press and release "REGEN". The words "REGEN TODAY" will flash in left corner of display as it scrolls through displays to indicate that the system will regenerate at the preset delayed regeneration time. If you pressed the "REGEN" button in error, pressing the button again will cancel the request. To initiate a manual regeneration immediately, press and hold the "REGEN" button for five seconds. The system will begin to regenerate immediately. The request cannot be cancelled. You must cycle all the way through the cycles to make it stop. PLEASE NOTE: This will reset the meter. Note: If the salt tank does not contain salt, fill with salt and wait at least two hours before regenerating. If two regenerations are desired within 24 hour period, press /release REGEN button. REGEN TODAY will flash on screen. Press and hold REGEN button until valve initiates an immediate regeneration.

# Maintenance

- 1) If your unit contains activated carbon, you should replace the carbon and gravel underbed at least every three years. Replacement may be required sooner if the taste and odor being removed begins to reappear in the treated water or you experience increasing pressure drop that is not resolved by increasing the frequency of backwashing.
- 2) Filter Ag, Zeolite and Filter Sand will last indefinitely. It may be necessary to replace them if you experience increasing pressure drop that is not resolved by increasing the frequency of backwashing or if water quality diminishes due to contaminant bleed through.
- 3) Iron Pro media or calcite will need replenished with neutralizer media (N05, MPH30 or C05P) regularly in low pH water. Mark the side of the mineral tank at installation so the drop in media level may be monitored by shining a bright light behind the mineral tank. Add media if the level has dropped by more than three inches.
- 4) Greensand Plus or KataloxLight should be replaced when iron reappears in the treated water and backwashing does not improve the water quality or excessive pressure loss is experienced.
- 5) Verify the unit draws air during the REGENERANT DRAW cycle at least every 12 months. Clean or replace the air check valve (OV15HT) and/or the injector (CV3010-11) and/or injector screen (CV3177-01), if needed.

## TO REPLENISH OR REBED MEDIA:

- 1) Pressure must be relieved on the system by placing the Bypass Valve in the "Bypass" position (Figure 3, Page 5) and initiating a manual regeneration (section 3, page 10).
- 2) Unplug the Control Valve from the electrical outlet to prevent it from advancing automatically.
- 3) Disconnect the Control Valve from the Bypass Valve. *If the unit has a "-DH" suffix in the model number and it only needs topped up with neutralizer media, DO NOT disconnect from the bypass valve.*
- 4) Disconnect the Drain Line from the Control Valve
- 5) Unscrew Control Valve from Mineral Tank **(IF REBEDDING ONLY! Remove the distributor)**. *If the unit has a "-DH" suffix in the model number and it only needs topped up with neutralizer, DO NOT remove the control valve, just unscrew the dome hole plug instead.*
- 6) Siphon water from Mineral Tank **(IF REBEDDING ONLY! Remove existing media and gravel)**.
- 7) **(IF REBEDDING ONLY! Rinse Mineral Tank and replace distributor, making certain that the distributor basket sits in the center of the tank bottom.)**
- 8) If the control valve was removed, cover the top of the distributor tube to prevent media entering the tube during filling. Using a funnel, pour filter media(s) into the mineral tank. **(IF REBEDDING ONLY! Begin loading the tank with the gravel underbed. Filling the Mineral Tank 1/3 with water before loading gravel will cushion the fall and ensure even distribution of the gravel and media. If using multiple filter media types, load in the order of heaviest {most dense} to lightest {least dense}.)** 14" of space MUST be left empty at the top of the mineral tank to allow for media bed expansion during backwash and to prevent filter media from being discharged through the drain line.
- 9) Use a garden hose or bucket to fill the media tank with water.
- 10) Clean mineral tank threads to remove any filter media. If control valve was removed, uncover distributor tube and reinstall control valve by threading it securely onto the mineral tank. "-DH" models that were only topped up with neutralizer on need the dome hole plug replaced. O-ring seal; HAND TIGHTEN ONLY in both cases!

## Maintenance (cont.)

- 11) If control valve was removed, attach bypass valve to control valve body.
- 12) If control valve was removed, reattach Drain Line to Control Valve (Figure 6, Page 7).
- 13) **IMPORTANT! Carbon, Filter Ag, Zeolite and Greensand Plus must be soaked for at least 2 hours prior to submitting it to full backwash flow rate to prevent loss of media to drain.**
- 14) Gradually turn the INLET side knob of the bypass valve counterclockwise not more than ½ way (45 degrees) to the “Service” position (Figure 2, Page 5) allowing unit to pressurize slowly. Check for leaks and correct as needed. Any air trapped in the media bed should begin purging to the drain and water should begin flowing to the drain.
- 15) Once the air is purged, gradually turn the INLET knob of the bypass valve counterclockwise until it is fully in “Service” position (Figure 2, Page 5). Then turn the OUTLET knob of the bypass valve counterclockwise until it is fully in the “Service” position (Figure 2, Page 5). and **leave the control valve in “Backwash” position for at least 10 minutes or until water flowing from the drain line runs clear; whichever is longer.**
- 16) Plug the transformer into the electrical outlet. Press the “REGEN” button to advance the control valve to the “RINSE” cycle. Another count-down timer will appear in the time-of-day position, “RINSE” will be shown in the lower middle of the display and “REGEN” appears in the middle left of the display. Allow the rinse cycle to complete and the filter will return to service mode automatically.

# Troubleshooting

PROBLEM	CAUSES	SOLUTIONS
Excessive pressure drop through filter	<ul style="list-style-type: none"> <li>A) Filter not backwashing</li> <li>B) Filter not backwashing frequently enough for water condition</li> <li>C) Filter bed loaded with sand</li> <li>D) "Cementing" or "Channeling"</li> <li>E) Drain Line restricted</li> <li>F) Control Valve plugged with debris</li> </ul>	<ul style="list-style-type: none"> <li>1) Check if display is blank, see "Blank Display" section of Page 14.</li> <li>2) Check if display has an error message, see "Error Code" section of Page 16.</li> <li>3) Verify drive motor is connected to circuit board connector J1 (labeled "MOTOR") and is not faulty</li> <li>4) Ensure uninterrupted power supply</li> <li>5) Increase Backwash frequency</li> <li>6) Verify sediment being removed is less dense than the filter media and install a "Spin-Down" type sediment filter ahead of the PIF1 to remove well sand</li> <li>7) Verify adequate pumping rate for backwash</li> <li>8) Probe media bed to check for "Cementing"</li> <li>9) Check drain line for restriction: frozen, plugged, kinked, exceeds 15', overhead installation, flexible drain line, drain line diameter too small</li> <li>10) Disassemble and clean control valve</li> </ul>
Contaminant not being properly removed	<ul style="list-style-type: none"> <li>A) Leaking bypass valve</li> <li>B) Internal valve leak</li> <li>C) Distributor tube not seated properly in control valve</li> <li>D) Water usage flow rate exceeds filter specifications</li> </ul>	<ul style="list-style-type: none"> <li>1) Verify bypass valve is in service position</li> <li>2) Replace piston and seal assemblies</li> <li>3) Verify distributor tube seated securely in control valve body</li> <li>4) Verify actual water usage flow rates against system specifications</li> <li>5) Increase length of backwash and rinse cycles</li> </ul>
Media raises pH too high	<ul style="list-style-type: none"> <li>A) Filter is brand new or newly re-bedded</li> <li>B) Wrong media used</li> </ul>	<ul style="list-style-type: none"> <li>1) Give the unit time for the pH to stabilize</li> <li>2) Re-bed the unit with a less aggressive media</li> </ul>
Media fails to raise pH sufficiently	<ul style="list-style-type: none"> <li>A) Water usage flow rate is too high to provide adequate contact time</li> <li>B) Media bed is "Cemented" or "Channeled"</li> </ul>	<ul style="list-style-type: none"> <li>1) Verify actual water usage flow rates against system specifications</li> <li>2) Verify adequate pumping rate for backwash</li> <li>3) Check drain line for restriction: frozen, plugged, kinked, exceeds 15', overhead installation, flexible drain line, drain line diameter too small</li> <li>4) Re-bed with a more aggressive media</li> </ul>
Filter fails to remove iron	<ul style="list-style-type: none"> <li>A) pH too low (&lt; 7)</li> <li>B) Insufficient air head</li> <li>C) Iron level or demand flow too high</li> </ul>	<ul style="list-style-type: none"> <li>1) Add MpH Adder to filter tank or install soda ash injection system before iron filter</li> <li>2) Install/replace inlet check valve, replace air check valve and/or injector, replace seals &amp; spacers</li> <li>3) Plumb a second unit in parallel</li> </ul>

## Troubleshooting (cont.)

PROBLEM	CAUSES	SOLUTIONS
Loss of media to drain	<ul style="list-style-type: none"> <li>A) Air in system</li> <li>B) Insufficient soak time before first backwash after installing media</li> </ul>	<ul style="list-style-type: none"> <li>1) Ensure well system has proper air elimination control</li> <li>2) Check media level and adjust if necessary</li> </ul>
Media in service lines	<ul style="list-style-type: none"> <li>A) Unit is installed backwards</li> <li>B) Distributor basket is broken</li> <li>C) Insufficient gravel under bed</li> </ul>	<ul style="list-style-type: none"> <li>1) Re-plumb the water lines so that the supply side of the line is connected to the inlet of the bypass and the service side is connected to the outlet.</li> <li>2) Replace distributor.</li> <li>3) Add gravel to tank, manually backwash</li> </ul>
Howling or whistling noise during regeneration	<ul style="list-style-type: none"> <li>A) Inadequate drain line diameter or drain line restricted</li> </ul>	<ul style="list-style-type: none"> <li>1) Reconfigure or replace drain line</li> </ul>
Continuous flow of water to drain	<ul style="list-style-type: none"> <li>A) Loss of electrical power during regeneration</li> <li>B) Debris in control valve</li> <li>C) Internal leak in control valve</li> </ul>	<ul style="list-style-type: none"> <li>1) Ensure electrical outlet is functioning</li> <li>2) Disassemble and clean control valve</li> <li>3) Replace seals and/or piston</li> </ul>
Filter backwashes at wrong time of day	<ul style="list-style-type: none"> <li>A) Clock is not set properly</li> <li>B) Power outage</li> <li>C) Incorrect control valve programming</li> </ul>	<ul style="list-style-type: none"> <li>1) Reset the clock (page 7)</li> <li>2) Verify control valve programming (page 8)</li> </ul>
Display is blank	<ul style="list-style-type: none"> <li>A) Control valve circuit board needs reset</li> <li>B) Transformer is unpowered, unplugged or defective</li> <li>C) Defective circuit board</li> </ul>	<ul style="list-style-type: none"> <li>1) Hold "NEXT" and "REGEN" buttons for 3 seconds</li> <li>2) Remove battery, unplug power for 5 seconds, plug back in, replace dead battery.</li> <li>3) Verify transformer is plugged into an electrical outlet that has power and transformer cable (black, 4 pins) is plugged into control valve connector J4 (labeled "POWER")</li> <li>4) With transformer plugged into electrical outlet, use a volt meter to test the 2 outer pins (furthest left and furthest right) of connector J4 on the control valve circuit board. Should be approximately 15 volts DC. Replace transformer if defective.</li> <li>5) Replace circuit board if needed</li> </ul>

## Troubleshooting (Error Codes)

ERROR CODE:	CAUSES	SOLUTIONS
<b>1001</b> – unable to sense motor movement	<ul style="list-style-type: none"> <li>A) Drive motor not inserted fully to engage pinion or is defective</li> <li>B) Circuit board not properly snapped into drive bracket</li> <li>C) Center reduction gear reflector dirty</li> </ul>	<ul style="list-style-type: none"> <li>1) Re-insert motor, check for broken wires, verify motor plugged into connector J1 (labeled “MOTOR”) on control valve circuit board and reset control valve (hold “NEXT” and “REGEN” buttons for 3 seconds)</li> <li>2) Re-seat circuit board into drive bracket and reset control valve</li> <li>3) Clean reduction gear reflectors (page 20)</li> </ul>
<b>1002</b> – unexpected motor stall	<ul style="list-style-type: none"> <li>A) Obstruction in control valve</li> <li>B) Main drive gear too tight</li> <li>C) Improper voltage delivered to circuit board</li> </ul>	<ul style="list-style-type: none"> <li>1) Remove piston and seal assemblies for inspection and repair or replacement and reset control valve (hold “NEXT” and “REGEN” buttons for 3 seconds)</li> <li>2) Loosen main drive gear and reset control valve</li> <li>3) Verify proper voltage is being supplied to circuit board (see Solution 4 under “Display is Blank” section, page 14)</li> </ul>
<b>1003</b> – motor ran too long, cannot find next cycle position	<ul style="list-style-type: none"> <li>A) Motor failure during regeneration</li> <li>B) Obstruction in control valve</li> <li>C) Drive bracket not snapped in place properly</li> </ul>	<ul style="list-style-type: none"> <li>1) Re-insert motor, check for broken wires, verify motor plugged into connector J1 (labeled “MOTOR”) on control valve circuit board and reset control valve (hold “NEXT” and “REGEN” buttons for 3 seconds)</li> <li>2) Remove piston and seal assemblies for inspection and repair or replacement and reset control valve</li> <li>3) Re-seat drive bracket assembly and reset control valve</li> </ul>
<b>1004</b> – motor ran too long, timed out trying to reach home position	<ul style="list-style-type: none"> <li>A) Drive bracket not snapped in place properly</li> <li>B) Center reduction gear reflector dirty</li> </ul>	<ul style="list-style-type: none"> <li>1) Re-seat drive bracket assembly and reset control valve (hold “NEXT” and “REGEN” buttons for 3 seconds)</li> <li>2) Clean reduction gear reflectors (page 20)</li> </ul>
<b>1006</b> – MAV/SEPS/NHBP/AUX MAV motor ran too long, looking for park position	<ul style="list-style-type: none"> <li>A) Control valve not programmed for ALT OFF</li> <li>B) Obstruction in control valve</li> </ul>	<ul style="list-style-type: none"> <li>1) Enter cycle programming level and verify second parameter is set to ALT OFF</li> <li>2) Remove piston and seal assemblies for inspection and repair or replacement and reset control valve (hold “NEXT” and “REGEN” buttons for 3 seconds)</li> </ul>
<b>1007</b> – MAV/SEPS/NHBP/AUX MAV motor ran too short looking for park position	<ul style="list-style-type: none"> <li>A) Control valve not programmed for ALT OFF</li> <li>B) Obstruction in control valve</li> </ul>	<ul style="list-style-type: none"> <li>1) Enter cycle programming level and verify second parameter is set to ALT OFF</li> <li>2) Remove piston and seal assemblies for inspection and repair or replacement and reset control valve (hold “NEXT” and “REGEN” buttons for 3 seconds)</li> </ul>



# SPECIFICATIONS

Description	PIF1-1054	PIF1-1248	PIF1-1354	PIF1-1465
<b>Filter Media Volume, cu. ft.</b>	1.0	1.5	2.0	2.5
<b>Gravel Underbed, lbs.</b>	20	25	25	30
<b>Operating Flow Rate, gpm</b>				
<b>Continuous</b> @ 5 gpm/ft <sup>2</sup> of media surface area	3	4	5	5
<b>Service</b> @ 10 gpm/ft <sup>2</sup> of media surface area	5	8	9	11
<b>Peak</b> @ 18 gpm/ft <sup>2</sup> of media surface area	10	14	17	19
<b>Backwash</b> @ 10 gpm/ft <sup>2</sup> of media surface area <b>NOTE: some medias may require a higher BW rate (in parenthesis)</b>	5.3 (9)	7.5 (11)	9 (13)	11 (15)
<b>Water Usage</b>				
Gallons (Gallons at higher BW flow)	99 (158)	134 (190)	158 (222)	190 (254)
<b>Service Pipe Size, in.</b>				
Standard	1	1	1	1
<b>Tank Diameter x Height, in.</b>	10 x 54	12 x 48	13 x 54	14 x 65
<b>Minimum Space Required, in.</b>				
Width	11	13	14	15
Depth	16	17	18	18
Height	66	60	66	77
<b>Approximate Ship Wt., lbs.</b> (Media Not Included)	68	68	73	85

**Factory default settings: Filtering type, 8 minute backwash, 14 minute regenerant draw, 8 minute rinse, 3 days between regenerations.**

Add "-DH" suffix for dome hole tank models. IE PIF1-1248-DH

All models include: CV3007 – 1" MNPT elbow adapters and QFNCR4-2 – 3/4" compression fittings for PEX, CPVC and copper.

# Component Parts Breakdown

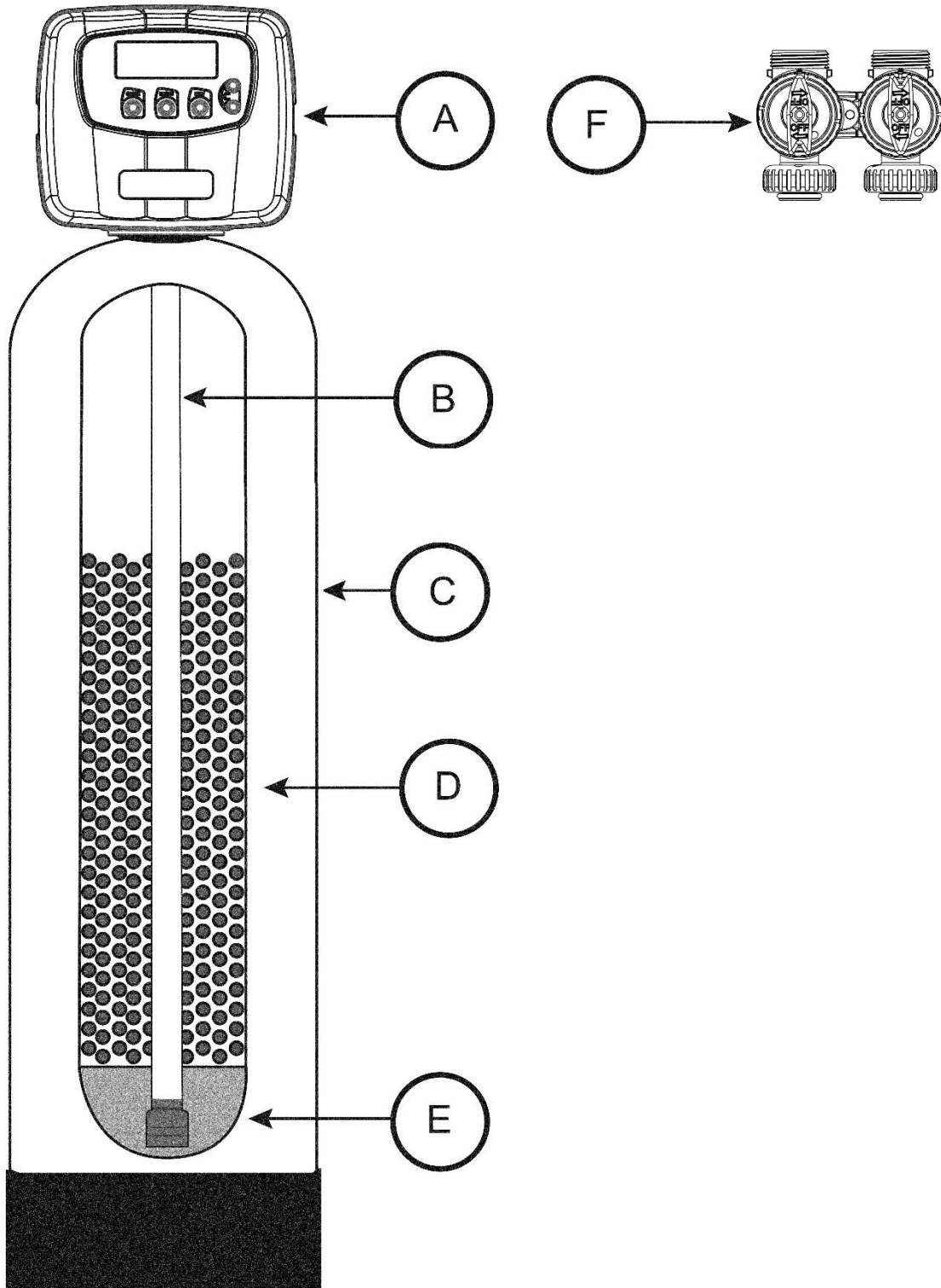

# Component Parts List

Ref #	Part Number	Description
A	PIF1-1054-VLV-L-BP	Control valve, cover, 5.3 GPM DLFC, less bypass for models PIF1-1054 & “-DH”
	PIF1-1248-VLV-L-BP	Control valve, cover, 7.5 GPM DLFC, less bypass for model PIF1-1248 & “-DH”
	PIF1-1354-VLV-L-BP	Control valve, cover, 9.0 GPM DLFC, less bypass for model PIF1-1354 & “-DH”
	PIF1-1465-VLV-L-BP	Control valve, cover, 11.0 GPM DLFC, less bypass for model PIF1-1465 & “-DH”
B	D100S-48	Distributor tube, 1" x 48" for models PIF1-1248 & “-DH”
	D100S-54	Distributor tube, 1" x 54" for models PIF1-1054, PIF1-1354 & “-DH”
	D100S-65	Distributor tube, 1" x 65" for model PIF1-1465 & “-DH”
C	MTP1054N	10 x 54 mineral tank, natural, base, 2.5" top opening for model PIF1-1054
	MTP1248N	12 x 48 mineral tank, natural, base, 2.5" top opening for model PIF1-1248
	MTP1354N	13 x 54 mineral tank, natural, base, 2.5" top opening for model PIF1-1354
	MTP1465N	14 x 65 mineral tank, natural, base, 2.5" top opening for model PIF1-1465
	MTP1054DOME	10 x 54 mineral tank, natural, base, 2.5" top opening for model PIF1-1054-DH
	MTP1248DOME	12 x 48 mineral tank, natural, base, 2.5" top opening for model PIF1-1248-DH
	MTP1354DOME	13 x 54 mineral tank, natural, base, 2.5" top opening for model PIF1-1354-DH
	T14X65T4DH	14 x 65 mineral tank, natural, base, 4.0" top opening for model PIF1-1465-DH (Requires C5148212 tank bushing adapter for 2.5" valve thread)
D*	A10	Activated Carbon, 1.00 cu. ft. bag
	A05P	Activated Carbon, 0.50 cu. ft. pail
	ACC10	Catalytic Carbon, 1.00 cu. ft. bag
	ACC05P	Catalytic Carbon, 0.50 cu. ft. pail
	C05P	Calcite, 0.50 cu. ft. pail
	FA10	Filter Ag, 1.00 cu. ft. bag
	FA05P	Filter Ag, 0.50 cu. ft. pail
	IP05	Iron Pro, 0.50 cu. ft. pail
	IP05M	Iron Pro M-bed, 0.50 cu. ft. pail
	K10	KataloxLight, 1.00 cu. ft. bag
	K05P	KataloxLight, 0.50 cu. ft. pail
	Z05P	Zeolite, 0.50 cu. ft. pail
	A8042	Greensand Plus, 0.50 cu. ft. bag
	QFS05P	Quartz Filter Sand, 0.50 cu. ft. pail
E	QC20	1/4" x 1/8" Gravel, 20 lb pail for models PIF1-1054 & “-DH”
	qty 1.25 - QC20	1/4" x 1/8" Gravel, 20 lb Pail for models PIF1-1248, PIF1-1354 & “-DH”
	qty 1.5 - QC20	1/4" x 1/8" Gravel, 20 lb Pail for models PIF1-1465 & “-DH”

\* Filter media sold seperately. Select appropriate media for water condition (page 2).

# Control Valve Breakdown

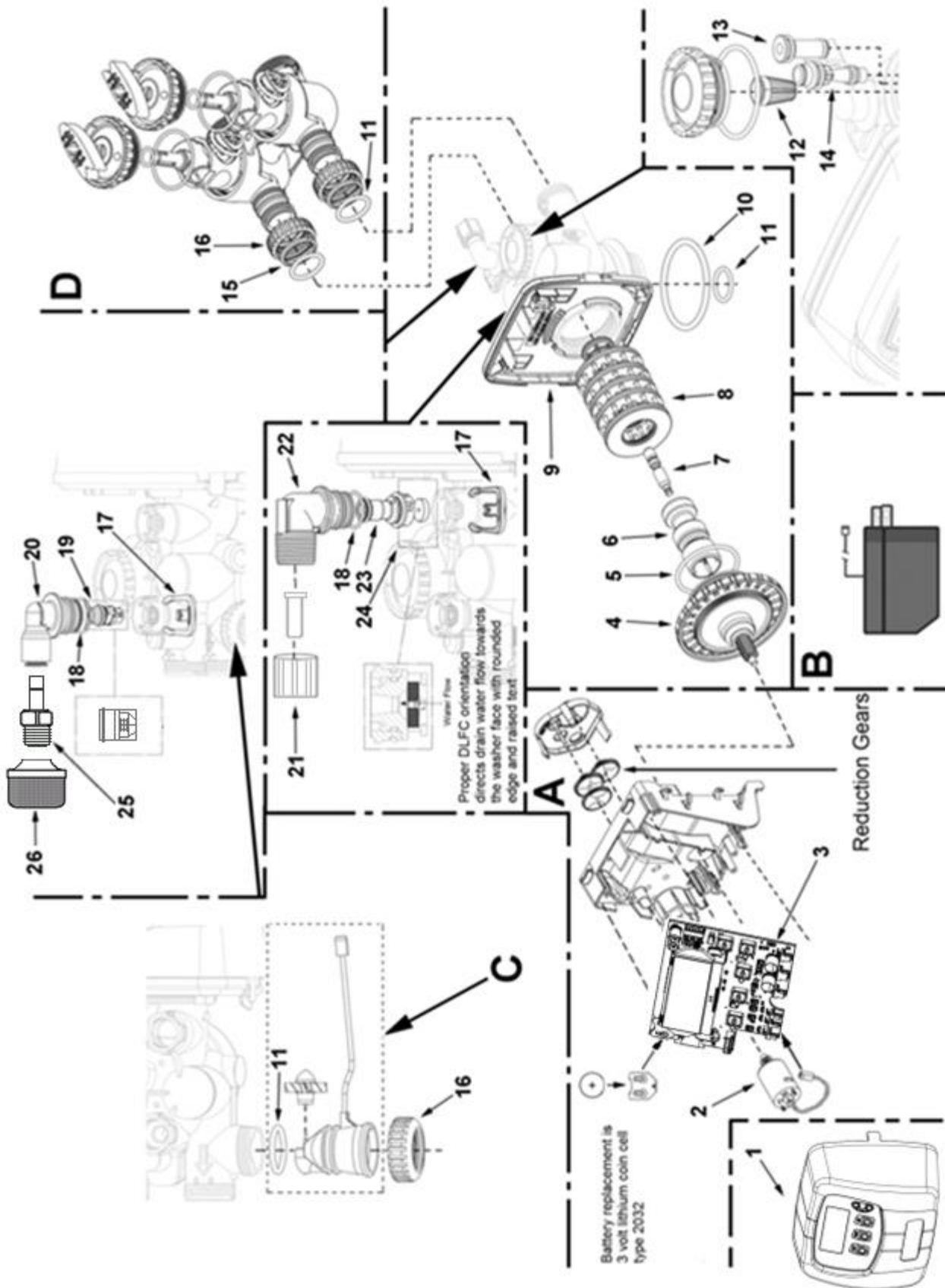

# Control Valve Parts List

REF #	Part Number	Description
A	CV3002-A	Drive Assembly (does not include circuit board or motor)
B	CV3186-06	Power Cord with Transformer, 15VDC
C	CV3003	Meter and Cable Assembly
D	CV3006	Bypass Valve, Less Fittings
1	CV3998-01FA	Front Cover, PXX1 Series
2	CV3107-01	Drive Motor
3	CV3578HP-02BOARD	Circuit Board, PXX1 Series
4	CV3004	Drive Cap Assembly
5	CV3135	O-ring, -228
6	CV3011	Piston Assembly
7	CV3174	Brine Valve
8	CV3005	Seal Cartridge Assembly
9	CV3946	Back Plate, PXX1 Series
10	CV3180	Base O-ring, -337
11	CV3105	O-ring, -215
12	CV3177-01	Injector Screen
13	CV3010-1Z	Plug, Injector Assembly
14	CV3010-1I	Injector, Orange
15	CV3150	Retainer, Split Ring
16	CV3151	Nut, 1" Quick Connect
17	CH4615	Clip, Elbow Locking
18	CV3163	O-ring, -019
19	OV15HT	Cartridge Check Valve, Brine Refill Port
20	CV4144	3/8" Elbow, Parker fitting
21	CV3192 PKP10TS8BULK	Compr. nut, 3/4" FNPT, for drain elbow (not used with CV3008-05) Insert, for 5/8" OD poly tube (not used with CV3008-05)
22 Not Shown	CV3158-02 CV3008-05	Elbow, Drain, 3/4" Male 1" NPT Straight Drain Fitting less DLFC for 11+ gpm BW flow rate
23	CV3159-01	Retainer, Drain Line Flow Control
24	CV3162-053 CV3162-075 CV3162-090 *CV3190-110  CV3162-090 *CV3190-110 *CV3190-130 *CV3190-150	<b>Drain Line Flow Control Button:</b> <b>For standard filter media</b> Flow Control Washer, 5.3 GPM (PIF1-1054) Flow Control Washer, 7.5 GPM (PIF1-1248) Flow Control Washer, 9.0 GPM (PIF1-1354) *Flow Control Washer, 11.0 GPM (PIF1-1465)  <b>For filter media requiring higher BW flow rate replace with:</b> Flow Control Washer, 9.0 GPM (PIF1-1054) *Flow Control Washer, 11.0 GPM (PIF1-1248) *Flow Control Washer, 13.0 GPM (PIF1-1354) *Flow Control Washer, 15.0 GPM (PBF1-1465) * requires 1" drain housing CV3008-05
25	6SA6	Stem Adapter
26	98755K12	Air Screen
Not Shown	OV32	Cartridge Check Valve, Control Valve Inlet

# Installation Fitting Assemblies

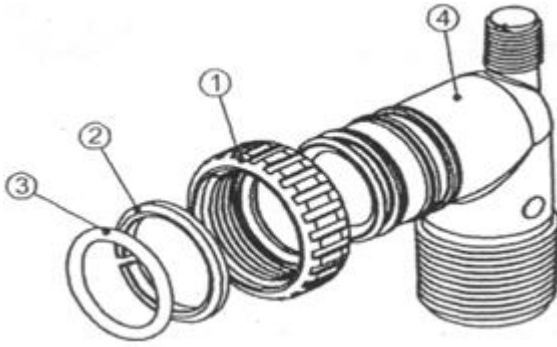

1" PVC MALE NPT ELBOW			
Ref	Part #	Description	Qty
	CV3007	1" PVC male NPT elbow assy	2
1	CV3151	Nut, 1" quick connect	2
2	CV3150	Split ring	2
3	CV3105	O-ring 215	2
4	CV3149	Fitting	2

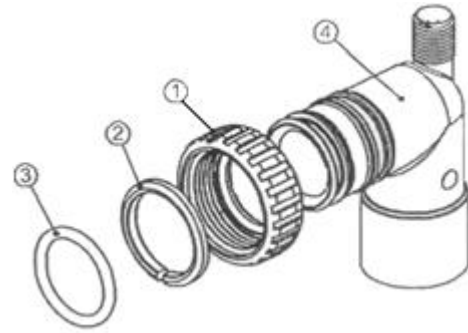

3/4" & 1" PVC SOLVENT ELBOW			
Ref	Part #	Description	Qty
	CV3007-01	3/4" & 1" PVC solvent elbow assy	2
1	CV3151	Nut, 1" quick connect	2
2	CV3150	Split ring	2
3	CV3105	O-ring 215	2
4	CV3189	Fitting	2

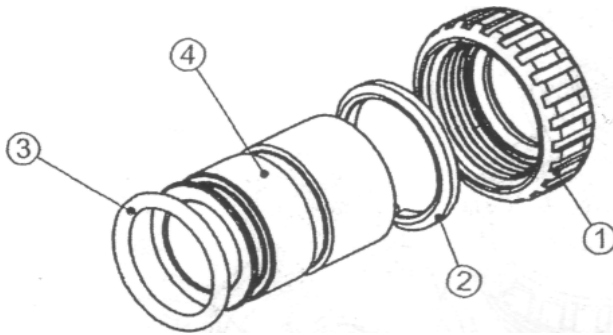

1" BRASS SWEAT			
Ref	Part #	Description	Qty
	CV3007-02	1" brass sweat assembly	2
1	CV3151	Nut, 1" quick connect	2
2	CV3150	Split ring	2
3	CV3105	O-ring 215	2
4	CV3188	Fitting	2

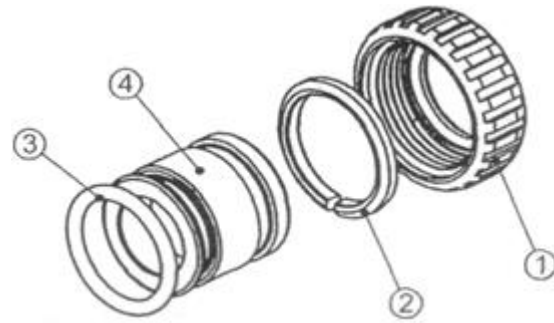

3/4" BRASS SWEAT			
Ref	Part #	Description	Qty
	CV3007-03	3/4" brass sweat assembly	2
1	CV3151	Nut, 1" quick connect	2
2	CV3150	Split ring	2
3	CV3105	O-ring 215	2
4	CV3188-01	Fitting	2

## Installation Fitting Assemblies (cont.)

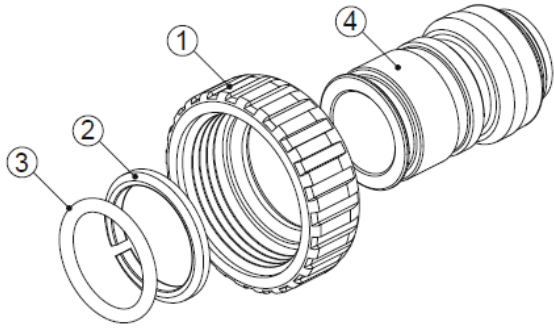

3/4" BRASS SHARK BITE			
Ref	Part #	Description	Qty
	CV3007-12	3/4" brass shark bite assembly	2
1	CV3151	Nut, 1" quick connect	2
2	CV3150	Split ring	2
3	CV3105	O-ring 215	2
4	CV3628	Fitting	2

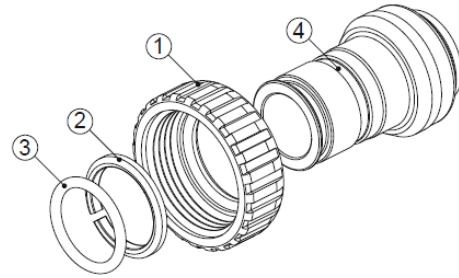

1" BRASS SHARK BITE			
Ref	Part #	Description	Qty
	CV3007-13	1" brass shark bite assembly	2
1	CV3151	Nut, 1" quick connect	2
2	CV3150	Split ring	2
3	CV3105	O-ring 215	2
4	CV3629	Fitting	2

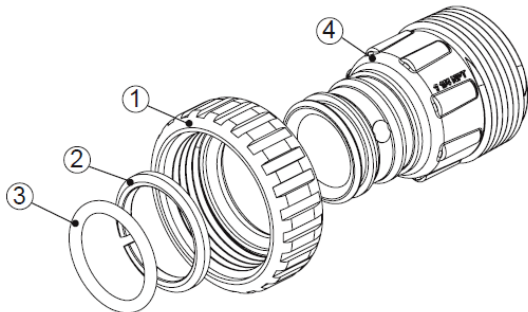

1-1/4" PLASTIC MALE NPT			
Ref	Part #	Description	Qty
	CV3007-04	1-1/4" plastic male NPT assembly	2
1	CV3151	Nut, 1" quick connect	2
2	CV3150	Split ring	2
3	CV3105	O-ring 215	2
4	CV3317	Fitting	2

# Installation Fitting Assemblies

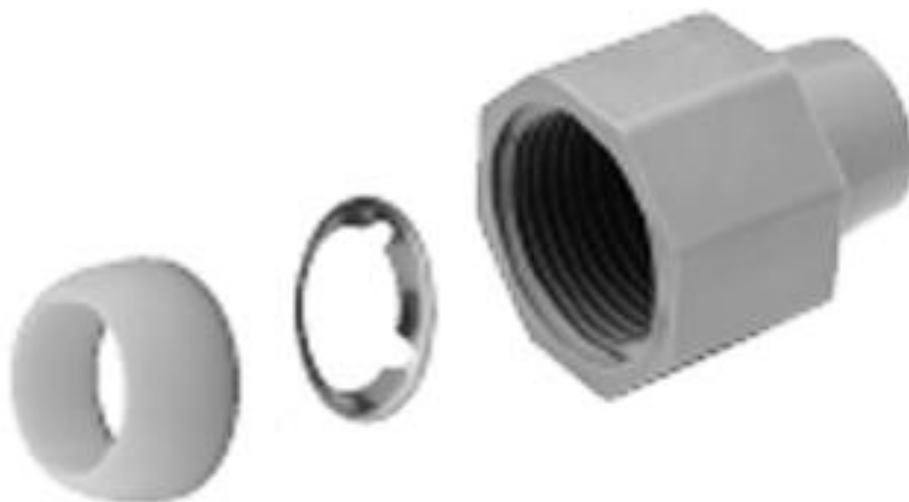

3/4" QUICK CONNECT			
Ref	Part #	Description	Qty
K	QFNCR4	3/4" QUICK CONNECT	1*

(\*2 required)

## SERVICE WRENCH - CV3193

Although no tools are necessary to assemble or disassemble the valve, the *Service Wrench*, (shown in various positions on the valve) is available to aid in assembly or disassembly.

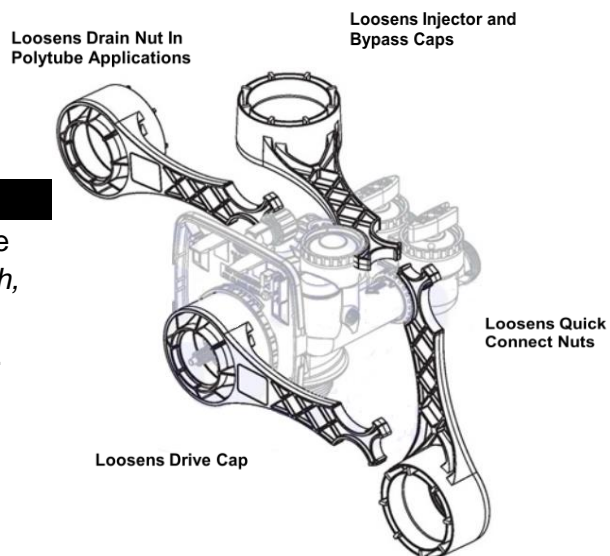



# TEN YEAR LIMITED WARRANTY

**WARRANTY – Franklin Water Treatment, LLC warrants this water conditioner against any defects that are due to faulty material or workmanship during the warranty period. This warranty does not include damage to the product resulting from accident, neglect, misuse, misapplication, alteration, installation, or operation contrary to printed instructions, or damage caused by freezing, fire, flood, or Acts of God. From the original date of consumer purchase, we will repair or replace, at our discretion, any part found to be defective within the warranty period described below. Purchaser is responsible for any shipping cost to our facility and any local labor charges.**

- One year on the entire water conditioner
- Five years on the control valve (except the seal & spacer kit - 1 year)
- Ten years on the mineral tank

**GENERAL CONDITIONS – Should a defect or malfunction occur, contact the dealer that you purchased the product from. If you are unable to contact the dealer, contact Franklin Water Treatment, LLC @ (260)693-1972. We will require a full description of the problem, model number, date of purchase, and selling dealer’s business name and address.**

We assume no warranty liability in connection with this water conditioner other than specified herein. This warranty is in lieu of all other warranties, expressed or implied, including warranties of fitness for a particular purpose. We do not authorize any person or representative to assume for us any other obligations on the sale of this water conditioner.

**FILL IN AND KEEP FOR YOUR RECORDS**

<b>Original Purchaser</b>	<b>Date of Purchase</b>	<b>Model #</b>	
<b>Address of Original Installation</b>		<b>City</b>	<b>State</b>
<b>Dealer Purchased From</b>	<b>Dealer Address</b>	<b>City</b>	<b>State</b>

Franklin Water Treatment, LLC  
12630 U.S. 33 North, Churubusco, IN 46723  
Phone: (260)693-1972 Fax: (260)693-0602