

Installation Instructions and Owner's Manual

SCT1 Series

Water Softener & Carbon Filter Combo



Franklin Water Treatment, LLC

12630 US Highway 33 N
Churubusco, IN 46723

Phone (260) 693-1972 Fax (260) 693-0602

Table of Contents

Pre-installation Instructions	Page 2
Typical Installation Illustration	Page 2
Bypass Valve	Page 5
Installation Instructions	Page 6
General Operation	Page 10
Installer Settings	Page 11
Manual Regeneration	Page 12
Maintenance	Page 13
Troubleshooting	Page 15
Specifications	Page 18
Component Parts Breakdown	Page 19
Component Parts List	Page 20
Control Valve Breakdown	Page 21
Control Valve Parts List	Page 22
Installation Fittings	Page 23
Ten Year Limited Warranty	Page 26

Pre-installation Instructions

Description of the water treatment system

This combo filter / softener system includes a brine (salt) tank, a carbon filter media tank and a softener resin tank with a backwashing control valve. Incoming water flows into the control valve and is directed down through the carbon and then the ion exchange softening resin. The carbon adsorbs chlorine to remove taste and odor and to protect the softener resin. The softener resin exchanges the hardness ions for softer ions. The softened water then returns to the control valve where it is directed into the service lines. The SCT1 Series carbon filter / water softener is designed to be installed on chlorinated water supplies.

Periodically the control valve will go through a regeneration cycle. The frequency of this regeneration process will depend on the size of water softener, incoming water quality and amount of water used. This cycle is factory preset to begin at 2:00 A.M. At this time the control valve will draw the brine solution out of the salt tank and flush both the accumulated hardness and excess salt to the drain. The control valve will then put fresh water back into the salt tank to make brine for the next regeneration cycle.

Water Quality

The water should be tested to determine the concentration, or levels of the items listed below:

Hardness - Hardness in drinking water is defined as those minerals that dissolve in water having a positive electrical charge (cat ions). The primary components of hardness are calcium (Ca++) and magnesium (Mg++) ions. But dissolved iron (Fe++) and manganese (Mn++) also contribute to total "adjusted" hardness. Hardness produces scale, soap scum and white mineral deposits which shorten the life of water using appliances, plumbing and fixtures. Water that has less than 1 grain of hardness is considered to be "soft" water.

pH - A measurement of the acidity of the water. pH is reported on a scale from 0 to 14. Neutral water has a pH of 7.0, lower values indicate acidic water. If your pH is below 6.8 you may consider installing an acid neutralizer before the water softener to elevate the pH.

Iron - A naturally occurring metallic element. Iron levels in excess of 0.3 milligrams/liter (mg/l) combine with oxygen causing orange or red (rust) stains on plumbing fixtures. Iron exists in some water sources in clear water (ferrous) state, red water (ferric) state or bacterial form. Iron levels that exceed 2.0 mg/l require special ion exchange resin for reduction, or if bacterial or ferric (red water) iron is present or iron level exceeds 4.0 mg/l, an iron filter should be installed ahead of this water softener.

Manganese - A naturally occurring metallic element. Manganese levels as low as 0.05 milligrams/liter (mg/l) can combine with oxygen to cause dark brown or black staining on fixtures. Additionally, manganese can cause an odor in the water similar to a "rotten egg" smell. This water softener may reduce manganese as well as iron; however, an iron filter may be required in some cases.

Tannin - A naturally occurring humic acid. Tannin is caused by water passing through decaying vegetation. Coffee and Tea are prime examples of tannin in water. Tannin levels as low as 0.5 milligrams per liter can cause a yellow discoloration in water. Consult your dealer for a system designed to remove both tannin and hardness.

Hydrogen Sulfide - A naturally occurring gas. Hydrogen sulfide, more commonly referred to as sulfur gas, causes a distinct odor similar to "rotten eggs." Due to its gaseous nature, hydrogen sulfide must be tested at the well site within 1 minute of drawing the sample. If sulfur is present additional equipment will be required. Air injection iron filters can typically treat up to 2 milligrams per liter of sulfur gas if regenerated daily. Specialty units can reduce higher amounts. Although carbon can reduce some sulfur, that is not the intended use for SCT1 units.

Pre-installation Instructions (cont.)

Location Considerations

The proper location to install the water softener system will ensure optimum performance and satisfactory water quality. The following factors should be considered in selecting the location of the equipment.

1. The water softener and filter system should be installed after the water meter on municipal water. Operating pressure of the softener must be limited to within 30 – 100 psi range.
2. The water softener and filter system should be installed as close as possible (preferably within 15') to an adequate floor or laundry drain capable of handling the backwash cycle volume and flow rate (refer to unit specifications).
3. All water conditioning equipment should be installed prior to the water heater. Water temperatures exceeding 100°F can damage the internal components of the control valve and filter tank. Install with at least 10' of pipe before the water heater to prevent thermal damage to the equipment. Otherwise, an expansion tank may need to be installed in the line to the water heater in order to allow for thermal expansion and comply with local plumbing codes.
4. The water softener should not be subject to freezing temperatures.
5. Ensure that any cartridge or in-line type filter installed prior to the water softener does not restrict the water flow and pressure available for backwash and interfere with normal operation.
6. Appliances requiring extended periods of continuous or high flow water use (i.e. geothermal heat pumps, swimming pools, lawn irrigation, outside hose bibs, etc.) should bypass the water softener.
7. Consider installing a vacuum breaker to prevent damage to the mineral tanks in the event of a water main break or check valve failure in a well system.

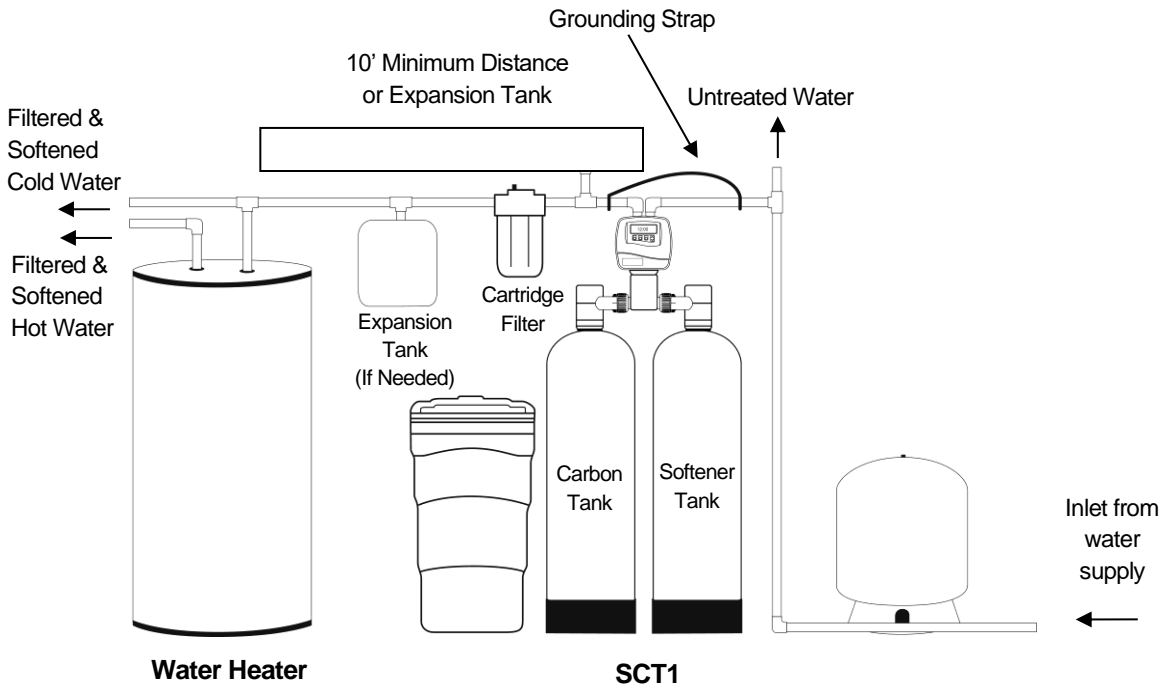

FIGURE 1: Typical Installation

General Installation

GENERAL INSTALLATION & SERVICE WARNINGS

The water conditioner is not designed to support the weight of plumbing.

Do not use Vaseline, oils, other hydrocarbon lubricants or spray silicone anywhere. A silicone lubricant may be used on black "O" Rings. This will allow ease of installation and decrease chance of rolling from the bypass and tank connections. *Avoid any type of lubricants, including silicone, on red or clear lip seals.*

Do not use pipe dope or other sealants on threads. Teflon® tape may be used as required. Teflon® tape is not used on any connection where "O" Ring seals are used

The nuts and caps are designed to be unscrewed or tightened by hand or with the special plastic Service Wrench, (CV3193, not included). If necessary, pliers can be used to unscrew the nut or cap. Do not use a pipe wrench to tighten nuts or caps. *Do not place screwdriver in slots on caps and/or tap with a hammer.*

NOTE: If the plumbing system is used as the ground leg of the electric supply, continuity should be maintained by installing ground straps around any non-conductive plastic piping or bypass used in the installation.

Make sure the filter is not installed backwards. The filter will not function properly if installed backwards and filter media may be forced into the service lines. Arrows molded into the valve body and red handles of the bypass indicate the direction of flow.

All local plumbing codes must be followed.

Bypass Valve

The bypass valve is used to isolate the control valve from the plumbing system's water pressure in order to perform control valve repairs or maintenance. The 1" full flow bypass valve incorporates four positions including a diagnostic position that allows a service technician to have pressure to test a system while providing untreated bypass water to the building. Be sure to install bypass valve onto main control valve, before beginning plumbing or make provisions in the plumbing system for a bypass. The bypass body and rotors are glass filled Noryl® and the nuts and caps are glass filled polypropylene. All seals are self-lubricating EPDM to help prevent valve seizing after long periods of non-use. Internal "O" Rings can easily be replaced if service is required. The bypass consists of two interchangeable plug valves that are operated independently by red arrow shaped handles. The handles identify the direction of flow. The plug valves enable the bypass valve to operate in four positions.

1. **Normal Operation Position:** The inlet and outlet handles point in the direction of flow indicated by the engraved arrows on the control valve. Water flows through the control valve for normal operation of a water softener or filter. During the regeneration cycle this position provides regeneration water to the unit, while also providing untreated water to the distribution system (**Fig. 2**).
2. **Bypass Position:** The inlet and outlet handles point to the center of the bypass. The system is isolated from the water pressure in the plumbing system. Untreated water is supplied to the building (**Fig. 3**).
3. **Diagnostic Position:** The inlet handle points toward the control valve and the outlet handle points to the center of bypass valve. Untreated supply water is allowed to flow to the system and to the building, while not allowing water to exit from the system to the building (**Fig. 4**). This allows the service technician to draw brine and perform other tests without the test water going to the building.

NOTE: The system must be run through a rinse cycle before returning the bypass valve to the normal position.

4. **Shut Off Position:** The inlet handle points to the center of the bypass valve and the outlet handle points away from the control valve. The water is shut off to the building. The water treatment system will depressurize upon opening a tap in the building. A negative pressure in the building combined with the softener being in regeneration could cause a siphoning of brine into the building. If water is available on the outlet side of the softener it is an indication of water bypassing the system (**Fig. 5**)

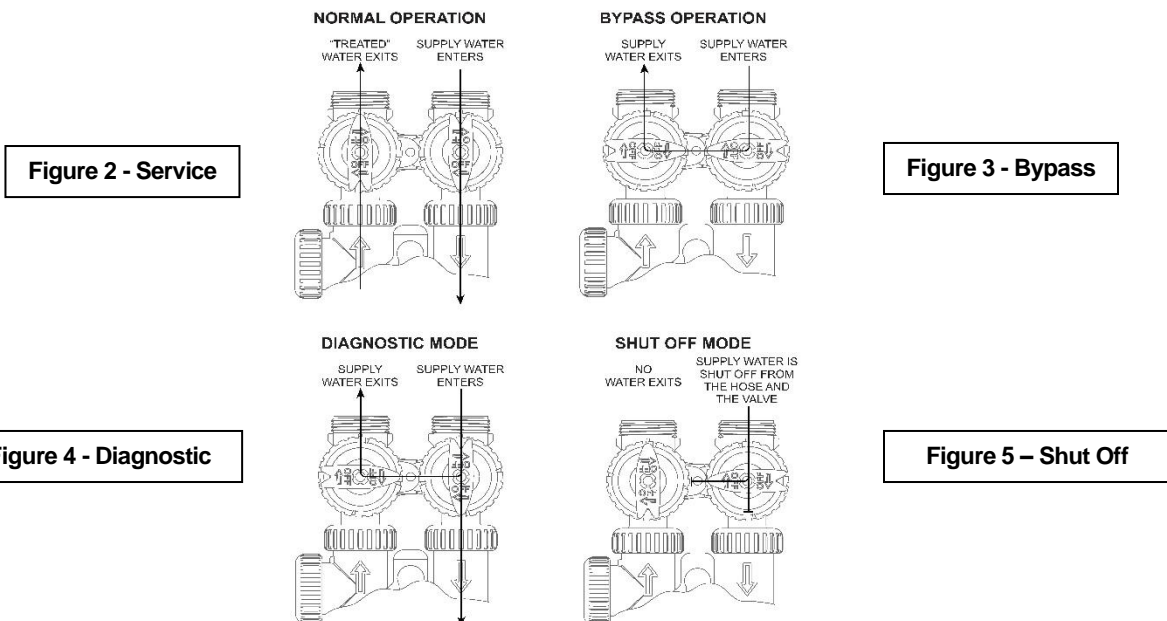

Installation Instructions

- STEP 1:** **Unpack SCT1 unit**, making sure to remove entire contents of the shipping container prior to disposal.
- STEP 2:** Place the tanks in the upright position. Use the provided wrench to **remove the fill port caps from the filter and softener tanks** (See Figure 6a, page 7) by turning it counter-clockwise.
- STEP 3:** If media is not already loaded, use the provided funnel to **pour carbon into the filter tank (left) and pour softener resin into the softener tank (right)**. At least 14" of space **MUST** be left empty at the top of the tank to allow for media bed expansion during backwash and to prevent media from being discharged to the drain or to the other tank.
- STEP 4:** Use a garden hose or bucket to **fill the media tanks with water**.
IMPORTANT: Carbon must be soaked for at least 2 hours prior to submitting it to full backwash flow rate to prevent loss of media to drain.
- STEP 5:** Clean fill port threads to remove any media. Lubricate the fill port cap o-ring with silicone grease. Replace the fill port caps using the provided wrench.
- STEP 6:** **Shut off all water at main supply**. On private well system, turn off power to pump and drain pressure tank. Make certain pressure is relieved from complete system by opening nearest faucet to drain system. **SHUT OFF FUEL / ELECTRICAL SUPPLY TO WATER HEATER.**
- STEP 7:** **Plumb the water supply line** to the unit's bypass valve inlet, located at the right rear as you face the unit. There are a variety of installation fittings available. They are listed under Installation Fitting Assemblies, pages 21-23. When assembling the installation fitting package (inlet and outlet), connect the fitting to the plumbing system first and then attach the nut, split ring, and "O" Ring. Heat from soldering or solvent cements may damage the nut, split ring, or "O" Ring. Solder joints should be cool and solvent cements should be set before installing the nut, split ring, and "O" Ring. Avoid getting solder flux, primer, and solvent cement on any part of the "O" Rings, split rings, bypass valve, or control valve. If the building's electrical system is grounded to the plumbing, install a copper grounding strap from the inlet to the outlet pipe. Plumbing must be done in accordance with all applicable local codes. **MAKE CERTAIN WATER ENTERS THROUGH INLET AND DISCHARGES THROUGH OUTLET.**
- STEP 8:** **Apply thread tape to DLFC Assembly**. Remove drain line flow control (DLFC) retainer clip (Figure 6b, Page 7) and remove the DLFC assembly from the valve body, (Figure 6b, Page 7). Apply thread tape to threads. Slide drain fitting compression nut onto provided drain tubing and place the tube insert inside the end of the tubing. Insert tubing end with insert into drain elbow and tighten the compression nut onto the thread taped elbow. Reinsert DLFC assembly into the valve body, making certain it is **FULLY** inserted before replacing the retaining clip.
- STEP 9:** **Install drain line**. Use the provided ½" I.D. polyethylene tubing (**DO NOT USE FLEXIBLE VINYL TUBING!**) to run drain line from control valve DLFC fitting (Figure 6b, Page 7) to floor drain or sump pit capable of handling the backwash rate of the filter (refer to specifications and flow rate on page 17) or discard the compression fitting and use the ¾" NPT fitting to connect a rigid pipe drain line . If backwash flow rate is greater than 7.5 gpm, use existing NPT connector with rigid drain line. There must be an air gap at the end of the drain line to prevent siphoning of wastewater. Length of drain line should be 15' or less. **AVOID OVERHEAD DRAINS.**

Installation Instructions (cont.)

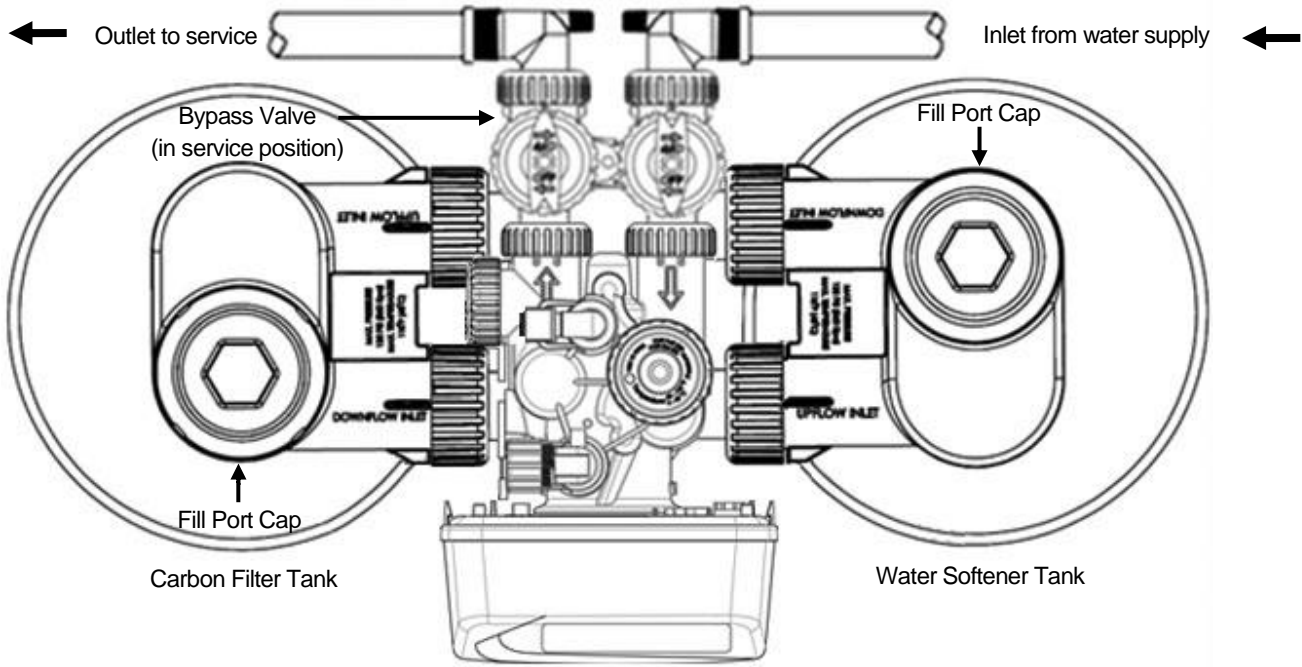

FIGURE 6a: Tank Positioning and Fill Port Location

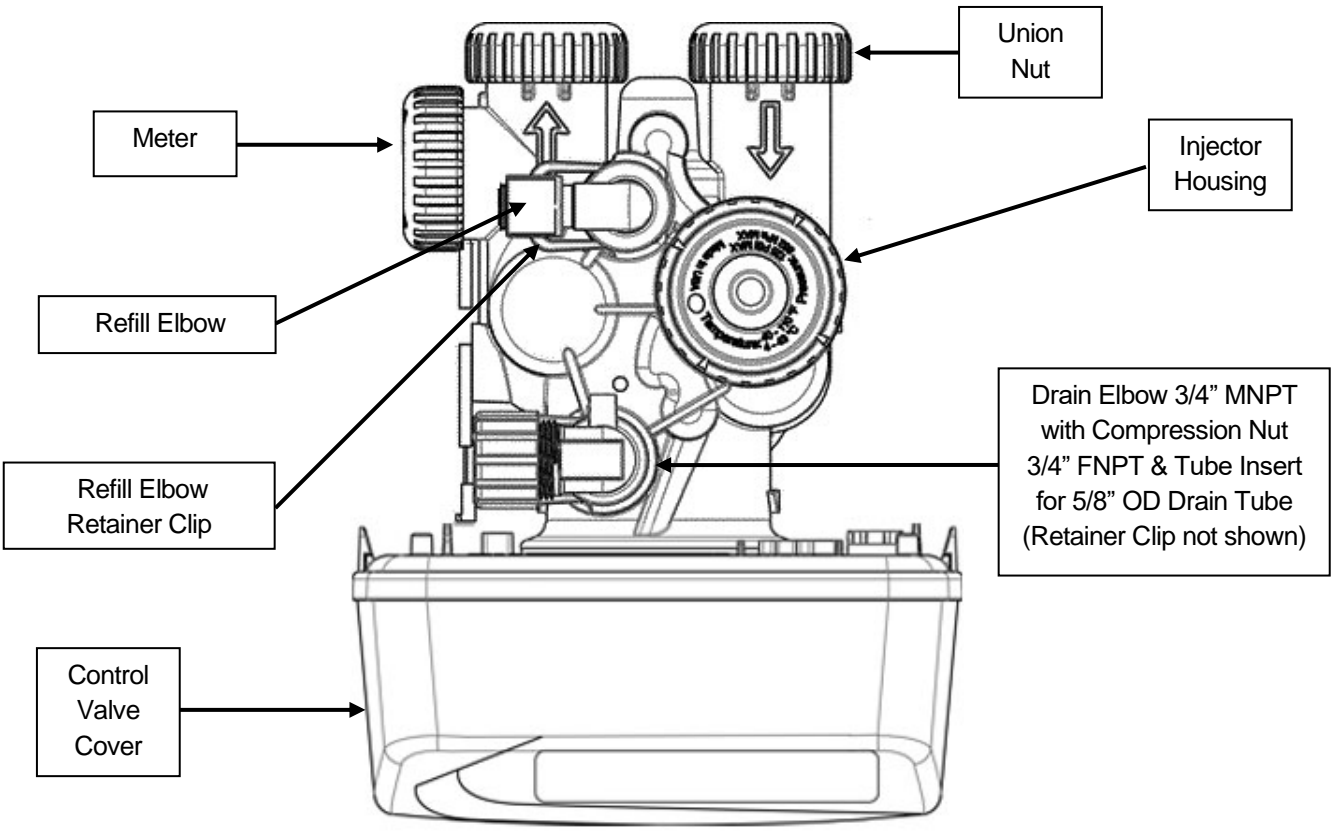

FIGURE 6b: Top View of Control Valve

Installation Instructions (cont.)

STEP 10: With the bypass valve handles in the bypass position (Figure 3, Page 5), turn on water supply. Turn the inlet bypass valve handle to the diagnostic position (Figure 4, Page 5) and allow the unit to pressurize. NOTE: the INLET and OUTLET knobs turn *clockwise* to close the port to the filter and *counter-clockwise* to open the port to the filter. Check for leaks and correct as needed. *Return the inlet bypass valve handle to the bypass position.*

STEP 11: Connect one end of the 3/8" brine line to the control valve quick connect brine refill elbow (Figure 6b, Page 7). Insert the other end of the brine line through the hole in the brine tank and into the quick connect fitting on the top of the safety brine valve (Figure 7). Remove the quick connect collet retainer clip (if included) before inserting the brine line into each fitting, press the tube in very firmly and replace the retainer clip behind the collet. **NOTE: THE BRINE TUBING SHOULD BE INSERTED 5/8" INTO THE FITTING. DO NOT PUT SALT INTO THE BRINE TANK AT THIS TIME.**

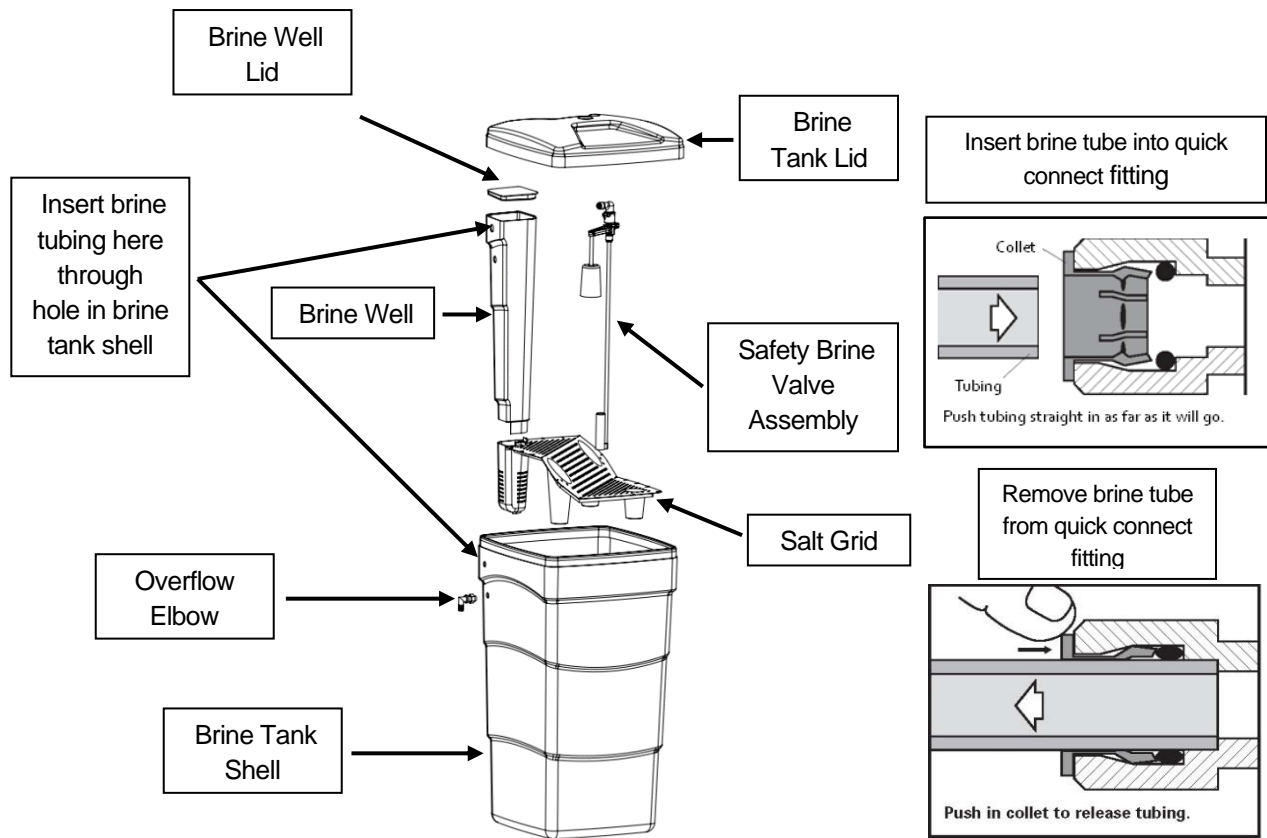

FIGURE 7: Brine Tank Components

STEP 12: If desired, install overflow tubing (not provided) from overflow elbow on brine tank (Figure 7) to floor drain. Tubing must be lower than the overflow elbow at all times. **DO NOT CONNECT DRAIN LINE FROM SOFTENER CONTROL VALVE TO BRINE TANK OVERFLOW. DO NOT CONNECT BRINE TANK DRAIN LINE TO THE SOFTENER DRAIN LINE.**

STEP 13: Plug the transformer into an un-switched electrical outlet. Ensure the control valve is in "Service" mode (time of day is displayed on the screen {refer to page 10 for General Operation}).

Detailed Installation Instructions (continued)

- STEP 14:** Place the bypass valve in the “Service” position (refer to Figure 2, Page 5; Figure 6a, Page 7) and open main supply valve or turn on power to pump on private well systems. Allow the unit to fill with water and pressurize, then place the bypass valve in the “Bypass” position (refer to Figure 3, Page 5).
- STEP 15:** Add water in the brine tank to slightly above the top level of the salt grid (approx. 6 gallons). **DO NOT ADD SALT TO THE BRINE TANK AT THIS TIME.**
- STEP 16:** With the bypass valve in the “Bypass” position (refer to Figure 3, Page 5), press and hold the REGEN button until the motor starts. Then use the REGEN button to advance the control valve to the BACKWASH cycle (refer to page 12 for details) to release pressure and purge air from the mineral tank.
- STEP 17:** Refer to Page 5 for bypass valve operation. Rotate the INLET knob of the bypass valve **slowly** to the “Service” position. If any air spurts or any media is expelled to the drain, stop turning the knob until only water flows to the drain, then continue turning the knob fully to the “Service” position.
- STEP 18:** When all air has been purged from the system and only water is running to the drain, turn the OUTLET knob of the bypass valve to the “Service” position also. Allow the system to backwash for a several minutes or until the drain water runs clear.
- STEP 19:** Using the REGEN button, advance the control valve to the BRINE DN (downflow brine draw) cycle. Verify that the water level in the brine tank is slowly dropping (less than ½ gpm). Allow water level to drop below the top of the salt grid before continuing. If the water level does not drop, refer to page 15 for Troubleshooting. After verifying water level is dropping advance the control valve past the BACKWASH 2, RINSE AND 5 second FILL cycle to the time of day, using the REGEN button.
- ADD SALT TO BRINE TANK NOW.** Any type of water softener salt may be used.
- STEP 20:** Check for leaks and correct as necessary.
- STEP 21:** Turn power or fuel supply back on to water heater.
- STEP 22:** Press and hold the NEXT and UP buttons together until the screen changes to input the adjusted hardness level water (refer to Installer Settings, Page 11, for details), then press NEXT repeatedly until the time of day is displayed.
- STEP 23:** Press the CLOCK button to set the current time of day. (Page 10, note AM and PM).
- STEP 24:** Verify the meter registers flow by opening a treated faucet and seeing that the word SOFTENING flashes on the display screen while water is flowing.

General Operation

When the system is operating one of two displays will be shown. Pressing NEXT will alternate between the displays. One of the displays is always the current time of day. The second display is gallons remaining. This is the number of gallons that can be treated before the system needs to go through a regeneration cycle.

The user can scroll between the displays as desired. If the system has called for a regeneration that will occur at the preset time of regeneration, the words "REGEN TODAY" will appear on the display.

When water is being treated (i.e. water is flowing through the system) the word "SOFTENING" flashes on the display.

REGEN TODAY will show if a regeneration is expected "Tonight."

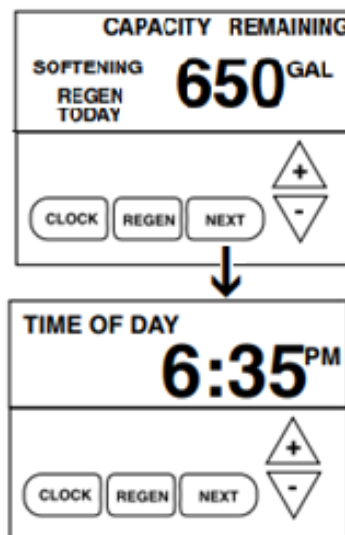

Set Time of Day

Step 1 - Press **CLOCK**.

Step 2 - Current Time (hour): Set the hour of the day using ▲ or ▼ buttons. AM/ PM toggles after 12. Press **NEXT** to go to step 3.

Step 3 - Current Time (minutes): Set the minutes of day using ▲ or ▼ buttons. Press **NEXT** to exit Clock. Press **REGEN** to return to previous step.

Power Loss - Lithium battery on circuit board provides up to 8 hours of time clock backup during power outages. After 8 hours, only the time of day needs to be reset, all other values are stored in non-volatile memory. If a power loss last less than 8 hours and time of day is flashing, replace coin type 2032 battery. Do not forget to reset for daylight savings time

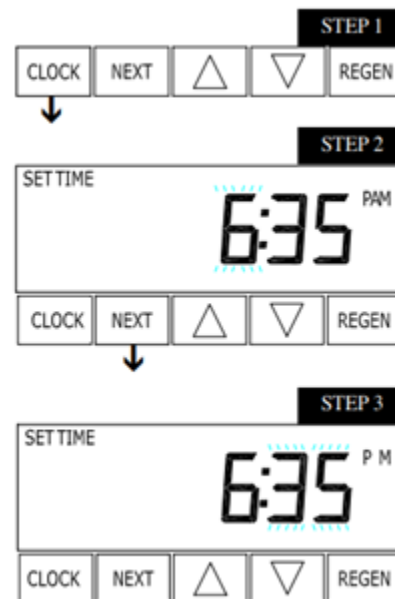

Installer Settings

Step 1 - Press **NEXT** and **▲** simultaneously for 3 seconds.

Step 2 - Hardness: Set the amount of adjusted hardness in grains per gallon (hardness gpg + (iron ppm x 3) + (manganese ppm x 5)) using **▲** or **▼** buttons. The default is 20 with value ranges from 1 to 150 in 1 grain increments. If this display shows “nA –”, then system is either set-up in “time clock” or “filter” modes. Press **NEXT** to go to Step 3. Press **REGEN** to exit Installer Settings.

Step 3 - Day Override: This sets the maximum number of days between regenerations. If value set to “oFF” regeneration is initiated automatically solely on gallons used. If value is set as a number (allowable range from 1 to 28) a regeneration will be initiated automatically on that day even if metered gallon usage does not trigger a regeneration. Press **NEXT** to go to step 4. Press **REGEN** to return to previous step.

Step 4 - Regeneration Time (hour): Set the hour of day for regeneration using **▲** or **▼** buttons. AM/PM toggles after 12. The default time is 2:00 a.m. This display will show “REGEN” on 0 GAL if system is set for immediate regeneration. Press **NEXT** to go to step 5. Press **REGEN** to return to previous step.

Step 5 - Regeneration Time (minutes): Set the minutes for the regeneration time using **▲** or **▼** buttons. This display will not be shown if system is set for immediate regeneration. Press **NEXT** to exit Installer Displays/Settings. Press **REGEN** to return to previous step.



Regeneration Display

Typically, a system is set to regenerate at a time of low water usage. An example of a time with low water usage is when the household is asleep. If there is a demand for water when the system is regenerating, untreated water will be supplied. When the system begins to regenerate, the display will change to include information about the step of the regeneration process and the time remaining for that step to be completed. The system runs through the steps automatically and will reset itself to provide treated water when the regeneration has been completed.



Manual Regeneration

Sometimes there is a need to regenerate the system, sooner than when the system calls for it, usually referred to as manual regeneration. There may be a period of heavy water usage because of guests or a heavy laundry day.

To initiate a manual regeneration at the preset delayed regeneration time, press and release **REGEN**. The words "REGEN TODAY" will flash on the display to indicate that the system will regenerate at the preset delayed regeneration time. If you pressed the **REGEN** button in error, pressing the button again will cancel the request.

To initiate a manual regeneration immediately, press and hold the **REGEN** button for three seconds. The system will begin to regenerate immediately. The request cannot be cancelled. You must cycle all the way through the cycles to make it stop. PLEASE NOTE: This will reset the meter. If back-to-back regenerations are desired, press and release **REGEN** button. "REGEN TODAY" will appear on screen. Push and hold **REGEN** button to initiate immediate regeneration. The softener will regenerate again at specified time. Back-to-back regenerations are recommended when salt is allowed to run out in brine tank. Make sure the brine tank contains salt before initiating a manual regeneration.



Maintenance

You will need to replace the carbon and gravel underbed at least every three years. Replacement may be required sooner if the taste and odor being removed begins to reappear in the treated water or you experience increasing pressure drop that is not resolved by increasing the frequency of backwashing.

TO REPLENISH OR REBED MEDIA:

- 1) Pressure must be relieved on the system by placing the Bypass Valve in the "Bypass" position (Figure 3, Page 5) and initiating a manual regeneration (section 3, page 12) and using the REGEN button to advance the control valve into a BACKWASH cycle.
- 2) Unplug the Control Valve from the electrical outlet to prevent it from advancing automatically.
- 3) Disconnect the filter tank fill port head at the union nuts.
- 4) Unscrew the filter tank head from the mineral tank and remove the distributor tube.
- 5) Siphon water from Mineral Tank. Remove existing media and gravel.
- 6) Rinse Mineral Tank and replace distributor, making certain that the distributor basket sits in the center of the tank bottom.
- 7) Cover the top of the distributor tube. Use a funnel to pour gravel and carbon into the mineral tank. Begin loading the tank with the gravel underbed. Filling the Mineral Tank 1/3 with water before loading gravel will cushion the fall and ensure even distribution of the gravel and media. At least 14" of space MUST be left empty at the top of the mineral tank to allow for media bed expansion during backwash and to prevent filter media from being discharged through the drain line.
- 8) Use a garden hose or bucket to fill the media tank with water.
- 9) Clean tank threads to remove any filter media. Uncover distributor tube and reinstall fill port head by threading it securely onto the mineral tank. Be careful not to cross-thread the tank. O-ring seal; **HAND TIGHTEN ONLY!**
- 10) Reattach fill port head at the union nuts.
- 11) **IMPORTANT! Carbon must be soaked for at least 2 hours prior to submitting it to full backwash flow rate to prevent loss of media to drain.**
- 12) **Initiate Manual Regeneration (Backwash Cycle):** With the bypass valve in the bypass position, press and hold the "REGEN" button until the drive motor starts. The drive motor will run briefly, and a count-down timer will appear in the lower right the display. Then press "REGEN" briefly at the countdown for both "FILL" and "SOFTENING" until the word "BACKWASH" appears in the upper left of the display and another countdown has begun.
- 13) **Unplug the transformer from the electrical outlet** to keep the SCT1 in backwash for an extended time to purge any air and remove media "fines" (very small particles of media).
- 14) Slowly turn the INLET knob of the bypass, counterclockwise, to a point approximately 1/3 of the way between "Bypass" and "Service" positions (Figure 2, Page 5) to release the remaining air from the tanks. Water should soon begin to flow (slowly) to the drain.
- 15)

Maintenance (cont.)

- 16) Once the air is purged, gradually turn the INLET knob of the bypass valve counterclockwise until it is fully in “Service” position (Figure 2, Page 5). Then turn the OUTLET knob of the bypass valve counterclockwise until it is fully in the “Service” position (Figure 2, Page 5). and **leave the control valve in “Backwash” position for several minutes or until water flowing from the drain line runs clear.**
- 17) **Plug the transformer into the electrical outlet.** Use the “REGEN” button to advance the control valve back to the service position where the time of day is displayed.
- 18) **Full Manual Regeneration:** Either press and hold the “REGEN” button to immediately initiate a full regeneration or briefly press the “REGEN” button to schedule a regeneration at the normal regeneration time. After this the filter will return to service mode automatically.

Troubleshooting

PROBLEM	CAUSES	SOLUTIONS
Brine tank overfills or does not draw brine	<ul style="list-style-type: none"> A) Loose nut at either end of the brine line B) Brine line inserted into the brine tank overflow fitting rather than connected to the safety brine valve C) Softener drain line connected to brine overflow fitting or overflow drain line D) Obstruction in the control valve E) Problems with drain line: plugged, frozen, kinked, flexible tubing, overhead installation, diameter too small, longer than 15' F) Missing BLFC G) Missing brine stem H) Dirty brine tank 	<ul style="list-style-type: none"> 1) Tighten nuts at either end of brine line 2) Verify brine line is installed correctly 3) Verify softener drain line is not connected to brine overflow elbow or brine overflow drain line 4) Check for debris in DLFC Assembly, BLFC Assembly, injector, injector screen 5) Manually put softener into Backwash Cycle (page 12) and unplug the transformer for 30 minutes to dislodge debris from inside the control valve or disassemble and clean control valve internal components 6) Resolve issues with the drain line 7) Verify brine line flow control button is not missing 8) Verify piston brine stem is not missing 9) Clean out brine tank
Hard water or softener not using salt	<ul style="list-style-type: none"> A) Softener is plugged into an electrical outlet without power or one that is tied to a switch B) No salt in the brine tank C) Salt in the brine tank has "bridged" D) Bypass Valve is not in "Service" position or is leaking E) Obstruction in control valve I) Problems with drain line: : (See letter "E" in prior section) F) Control valve programmed incorrectly G) Softener sized improperly for actual service flow rates H) Faulty or unplugged drive motor I) Meter cable disconnected 	<ul style="list-style-type: none"> 1) Verify softener has uninterrupted power 2) Fill brine tank with salt 3) Hit the side of the brine tank with rubber mallet to break any bridging that has formed in the brine tank 4) Verify bypass is in "Service" position (Figure 2, Page 5) 5) Check for debris in DLFC Assembly, BLFC Assembly, injector, injector screen 6) Manually put softener into Backwash Cycle (page 12) and unplug transformer for 20-30 minutes to dislodge debris 7) Resolve issues with drain line 8) Review control valve programming 9) Verify actual service flow rates required and compare to system specifications (page 18) 10) Verify drive motor is connected to control valve circuit board connector J1 (labeled "MOTOR") 11) Verify meter cable (grey cable, 3 pins) is connected to control valve circuit board connector J2 (labeled "METER")

Troubleshooting (cont.)

PROBLEM	CAUSES	SOLUTIONS
Softener regenerates at wrong time of day	<ul style="list-style-type: none"> A) Clock is not set B) Power outage C) Incorrect control valve programming 	<ul style="list-style-type: none"> 1) Reset softener clock (page 10) 2) Verify control valve programming (page 11, Installer Settings)
Resin in water lines, plugged aerators	<ul style="list-style-type: none"> A) Unit is installed backwards B) Distributor basket is damaged 	<ul style="list-style-type: none"> 1) Re-plumb unit with water supply entering bypass inlet (page 5) 2) Replace damaged distributor basket
Salty Water	<ul style="list-style-type: none"> A) Brine tank overfilled B) Problems with drain line: (See Letter "E" in Brine Tank Overfill section) C) Rinse cycle is short D) Salt setting too high E) Distributor tube improperly seated in control valve or is too short F) Low water pressure 	<ul style="list-style-type: none"> 1) See "Brine tank overfills" section (Page 15) 2) Resolve drain line issues 3) Contact technical support for assistance in verifying \ adjusting Rinse Cycle length and Salt Setting 4) Verify proper installation of distributor tube 5) Verify at least 25 psi of line pressure
Softener leaks to drain in "Service" position	<ul style="list-style-type: none"> A) Problem in piston cartridge assembly B) Control valve is jammed or halted during regeneration C) Drive cap assembly is not tightened properly 	<ul style="list-style-type: none"> 1) Replace seals and/or piston if needed 2) Verify control valve is in "SOFTENING" mode 3) Tighten drive cap assembly
Low water pressure	<ul style="list-style-type: none"> A) Iron or sediment build up in softener B) Insufficient pump capacity 	<ul style="list-style-type: none"> 1) Increase backwash frequency by increasing hardness setting (page 11) 2) Verify at least 25 psi of line pressure
Display is blank	<ul style="list-style-type: none"> A) Control valve circuit board needs reset B) Transformer is unpowered, unplugged or defective C) Defective circuit board 	<ul style="list-style-type: none"> 1) Hold "NEXT" and "REGEN" buttons for 3 seconds 2) Remove battery, unplug power for 5 seconds, plug back in, replace dead battery 3) Verify transformer is plugged into an electrical outlet that has power and transformer cable (black, 4 pins) is plugged into control valve connector J4 (labeled "POWER") 4) With transformer plugged into electrical outlet, use a volt meter to test the 2 outer pins (furthest left and furthest right) of connector J4 on the control valve circuit board. Should be approximately 15 volts DC. Replace transformer if defective. 5) Replace circuit board if needed
"SOFTENING" does not display when water is flowing	<ul style="list-style-type: none"> A) Bypass valve not in "Service" position B) Meter cable disconnected C) Restricted/stalled meter turbine D) Defective meter E) Defective PC board 	<ul style="list-style-type: none"> 1) Verify bypass is in "Service" position (Figure 2, Page 5) 2) Verify meter cable (grey cable, 3 pins) is connected to control valve circuit board connector J2 (labeled "METER") 3) Remove meter and check for restriction 4) Replace meter if needed 5) Replace PC board if needed

Troubleshooting (cont.)

PROBLEM	CAUSES	SOLUTIONS
Display shows incorrect time-of-day or time-of-day flashes	<ul style="list-style-type: none"> A) Outlet is on a switch B) Power outage C) Control valve was reset D) Defective circuit board 	<ul style="list-style-type: none"> 1) Use an un-switched outlet 2) Reset time-of-day 3) Replace circuit board if needed
ERROR CODE:		
1001 – unable to sense motor movement	<ul style="list-style-type: none"> A) Drive motor not inserted fully to engage pinion or is defective B) Circuit board not properly snapped into drive bracket C) Center reduction gear reflector dirty 	<ul style="list-style-type: none"> 1) Re-insert motor, check for broken wires, verify motor plugged into connector J1 (labeled “MOTOR”) on control valve circuit board and reset control valve (hold “NEXT” and “REGEN” buttons for 3 seconds) 2) Re-seat circuit board into drive bracket and reset control valve 3) Clean reduction gear reflectors (page 21)
1002 – unexpected motor stall	<ul style="list-style-type: none"> A) Obstruction in control valve B) Main drive gear too tight C) Improper voltage delivered to circuit board 	<ul style="list-style-type: none"> 1) Remove piston and seal assemblies for inspection and repair or replacement and reset control valve (hold “NEXT” and “REGEN” buttons for 3 seconds) 2) Loosen main drive gear and reset control valve 3) Verify proper voltage is being supplied to circuit board (see Solution 4 under “Display is Blank” section, page 16)
1003 – motor ran too long, cannot find next cycle position	<ul style="list-style-type: none"> A) Motor failure during regeneration B) Obstruction in control valve C) Drive bracket not snapped in place properly 	<ul style="list-style-type: none"> 1) Re-insert motor, check for broken wires, verify motor plugged into connector J1 (labeled “MOTOR”) on control valve circuit board and reset control valve (hold “NEXT” and “REGEN” buttons for 3 seconds) 2) Remove piston and seal assemblies for inspection and repair or replacement and reset control valve 3) Re-seat drive bracket assembly and reset control valve
1004 – motor ran too long, timed out trying to reach home position	<ul style="list-style-type: none"> A) Drive bracket not snapped in place properly B) Center reduction gear reflector dirty 	<ul style="list-style-type: none"> 1) Re-seat drive bracket assembly and reset control valve (hold “NEXT” and “REGEN” buttons for 3 seconds) 2) Clean reduction gear reflectors (page 21)
1006 – MAV/SEPS/NHBP/AUX MAV motor ran too long, looking for park position	<ul style="list-style-type: none"> A) Control valve not programmed for ALT OFF B) Obstruction in control valve 	<ul style="list-style-type: none"> 1) Enter cycle programming level and verify second parameter is set to ALT OFF 2) Remove piston and seal assemblies for inspection and repair or replacement and reset control valve (hold “NEXT” and “REGEN” buttons for 3 seconds)
1007 – MAV/SEPS/NHBP/AUX MAV motor ran too short looking for park position	<ul style="list-style-type: none"> A) Control valve not programmed for ALT OFF B) Obstruction in control valve 	<ul style="list-style-type: none"> 1) Enter cycle programming level and verify second parameter is set to ALT OFF 2) Remove piston and seal assemblies for inspection and repair or replacement and reset control valve (hold “NEXT” and “REGEN” buttons for 3 seconds)

SPECIFICATIONS

Description	SCT1-0948	SCT1-1054	SCT1-1248	SCT1-1354
Media Volume, cu. ft. per tank	1.0	1.5	2.0	2.5
Gravel Underbed, lbs.	15	20	25	30
Water Softener Capacity, grains				
@Factory Salt	24,000	36,000	48,000	60,000
@Max. Salt @ 15lb/ft3	30,000	45,000	60,000	75,000
Operating Flow Rate, gpm				
Continuous (3 gpm/ft3)	3	5	6	8
Service (<=8 gpm/ft3, <15psi drop)	8	12	16	18
Peak (<20 psi drop)	18	18	22	22
Regen. Flow Rates, gpm				
Backwash & Rapid Rinse	2.7	3.2	5.3	5.3
Injector	Yellow	Orange	Orange	Lt Blue
Brine Draw - Rinse (@ 50 psi)	0.43-0.64	0.60-1.05	0.60-1.05	0.70-1.35
Service Pipe Size, in.	1" & 3/4"	1" & 3/4"	1" & 3/4"	1" & 3/4"
Factory Regeneration Settings				
Brine Tank Fill (lbs of salt)	9	13.5	18	22.5
Softening (minutes dissolving salt)	120	120	120	120
P Code	P17	P29	P14	P40
Backwash (minutes)	8	12	8	11
Brine Draw & Rinse (minutes)	65	60	60	75
Backwash 2 (minutes)	8	8	6	8
Rapid Rinse (minutes)	5	8	6	7
Total Water Used, gallons	102	148	163	230
Dimensions (inches)				
Mineral Tank, diameter x height	9 x 48	10 x 54	12 x 48	13 x 54
Brine Tank, width x depth x height	18X18X33	18X18X33	18X18X33	18X18X33
Overall, depth x width x height:	42 x 18 x 64	43 x 18 x 70	48 x 18 x 64	49 x 18 x 70
Approx. Shipping Weight	175	250	300	325

All models include: CV3007 – 1" MNPT elbow adapters and QFNCR4-2 – 3/4" compression fittings for PEX, CPVC and copper.

Component Parts Breakdown

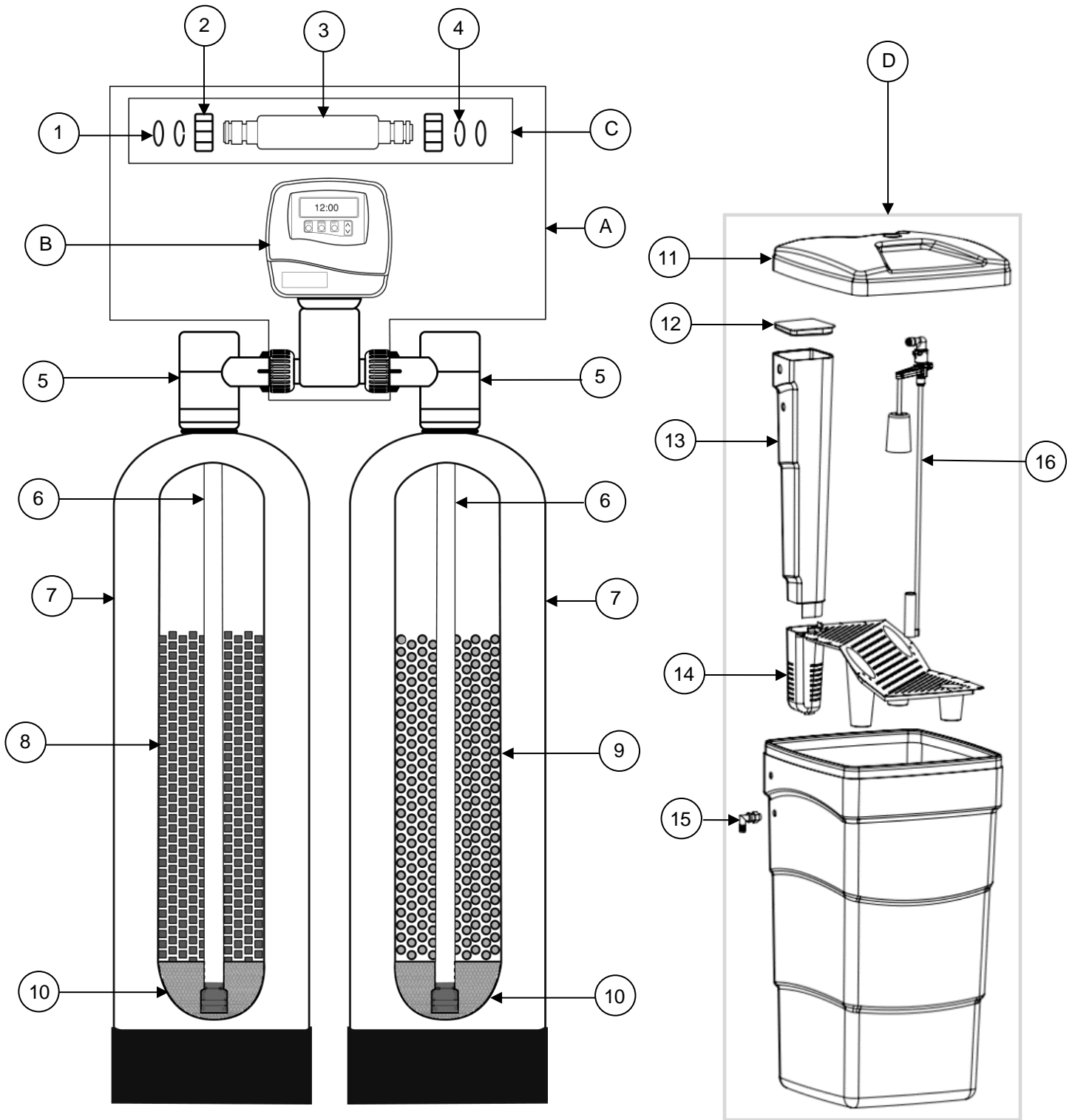

Component Parts List

Ref #	Part Number	Description
A	SCT1-0948A-VLV-W-BP-	Complete Valve Assembly, includes sump, backtube assy & bypass valve with fittings (SCT1-0948)
	SCT1-1054A-VLV-W-BP-	Complete Valve Assembly , includes sump, backtube assy & bypass valve with fittings (SCT1-1054)
	SCT1-1248A-VLV-W-BP-	Complete Valve Assembly , includes sump, backtube assy & bypass valve with fittings (SCT1-1248)
	SCT1-1354A-VLV-W-BP-	Complete Valve Assembly , includes sump, backtube assy & bypass valve with fittings (SCT1-1354)
B	SCT1-0948-VLV-L-BP-	Control Valve Only, less bypass (SCT1-0948)
	SCT1-1054-VLV-L-BP-	Control Valve Only, less bypass (SCT1-1054)
	SCT1-1248-VLV-L-BP-	Control Valve Only, less bypass (SCT1-1248)
	SCT1-1354-VLV-L-BP-	Control Valve Only, less bypass (SCT1-1354)
C	DTC204-8	Back Tube Assembly, includes 2 each o-rings (1), quick release nuts (2), and retainers (4) and 1 back tube (3)
D	BTSQ1833ASSY-	Brine Tank Assembly, 18"x33"
1	OR323	O-Ring, -323
2	C102	Connector Nut
3	DTC204-8	Dual Tank Connector
4	C101	Split Ring Retainer
5	FP207	Distributor Head w/Fillport
6	D100S-54	Distributor Tube, 1" x 54" (SCT1-1054, SCT1-1354)
	D100S-48	Distributor Tube, 1" x 48" (SCT1-0948, SCT1-1248)
7	MTP0948GR	Mineral Tank, 9" x 48" (SCT1-0948)
	MTP1054GR	Mineral Tank, 10" x 54" (SCT1-1054)
	MTP1248GR	Mineral Tank, 12" x 48" (SCT1-1248)
	MTP1354GR	Mineral Tank, 13" x 54" (SCT1-1354)
8	QTY 2 – A05P	0.5 cu ft pails, GAC (SCT1-0948)
	QTY 3 – A05P	0.5 cu ft pails, GAC (SCT1-1054)
	QTY 4 – A05P	0.5 cu ft pails, GAC (SCT1-1248)
	QTY 5 – A05P	0.5 cu ft pails, GAC (SCT1-1354)
9	QTY 2 – H05P	0.5 cu ft pails, Hi Cap Resin (SCT1-0948)
	QTY 3 – H05P	0.5 cu ft pails, Hi Cap Resin (SCT1-1054)
	QTY 4 – H05P	0.5 cu ft pails, Hi Cap Resin (SCT1-1248)
	QTY 5 – H05P	0.5 cu ft pails, Hi Cap Resin (SCT1-1354)
10	QTY 1 – QC20	20 lb pail, gravel (SCT1-0948, SCT1-1054, SCT1-1248)
	QTY 1-1/2 – QC20	20 lb pail, gravel (SCT1-1654)
11	BTSQ18L	Brine Tank Lid
12	BTBWL-18	Brine Well Lid
13	BW-4	Brine Well
14	BTSG18SQ	Salt Grid, 18" Square Brine Tank
15	BT-OVERFLO	Brine Tank Overflow Fitting
16	SBV14ASSY	Safety Brine Valve Assembly
NOT SHOWN	Qty 2 - FPS101	Top Screens, installed in fill port heads

Control Valve Breakdown

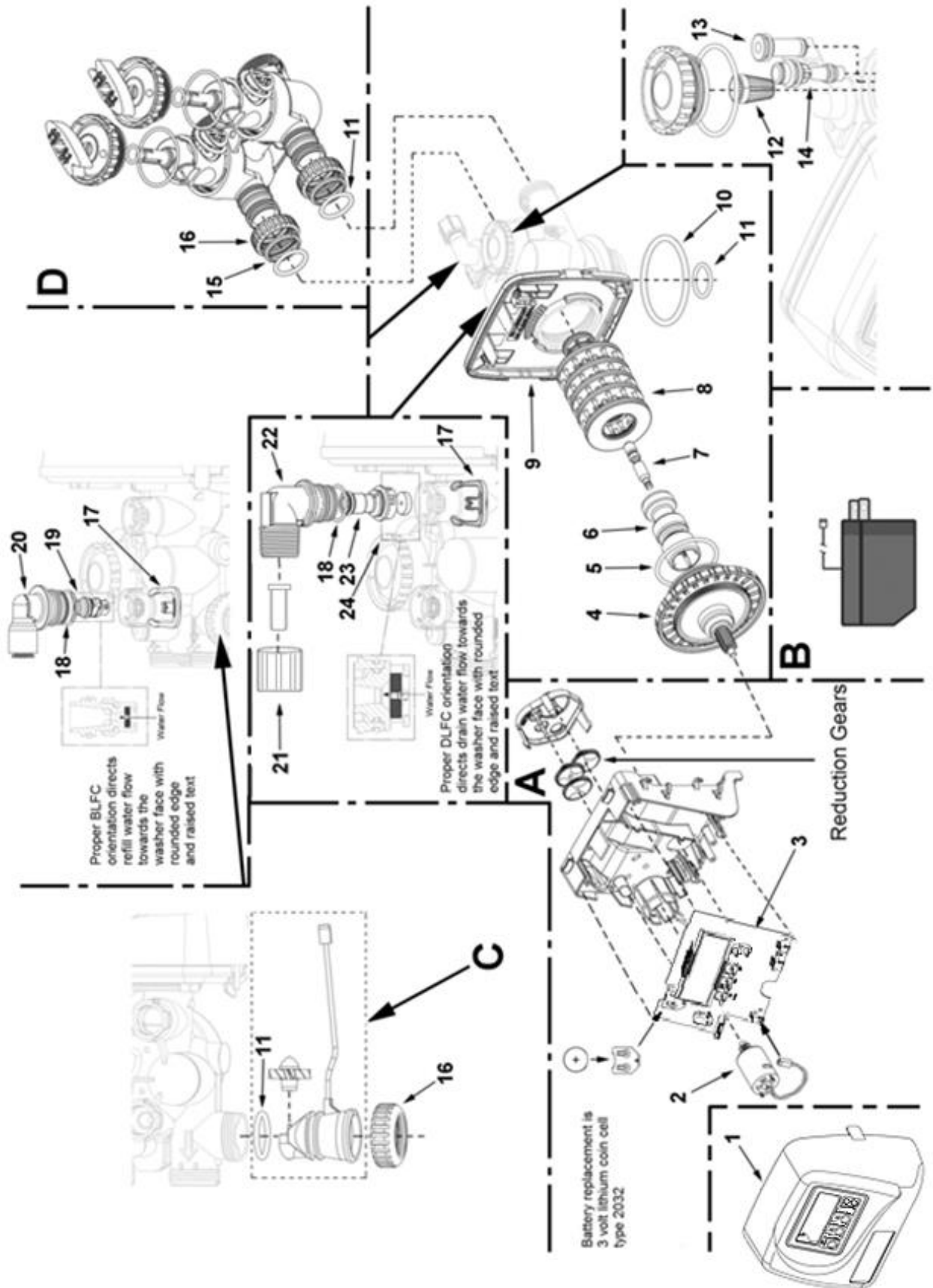

Control Valve Parts List

REF #	Part Number	Description
A	CV3002SWS1	Drive Assembly, SWS1 Series
B	CV3186-06	Power Cord with Transformer, 15 VDC
C	CV3003	Meter and Cable Assembly
D	CV3006	Bypass Valve, Less Fittings
1	CV3992-01	Front Cover, Black, SWS Series
2	CV3107-01	Drive Motor
3	CV3940HC-01BOARD	Circuit Board, SWS Series
4	CV3004	Drive Cap Assembly
5	CV3135	O-ring, -228
6	CV3011	Piston Assembly
7	CV3174	Brine Valve
8	CV3005	Seal Cartridge Assembly
9	CV3178	Back Plate
10	CV3180	Base O-ring, -337
11	CV3105	O-ring, -215
12	CV3177-01	Injector Screen
13	CV3010-1Z	Plug, Injector Assembly
14	CV3010-1G CV3010-1I CV3010-1J	Injector, Yellow (SCT1-30) Injector, Orange (SCT1-45, SCT1-60) Injector, Lt Blue (SCT1-75)
15	CV3150	Retainer, Split Ring
16	CV3151	Nut, 1" Quick Connect
17	CH4615	Clip, Elbow Locking
18	CV3163	O-ring, -019
19	CV3165-01	Retainer, Brine Refill Flow Control
20	CV4144	3/8" Elbow, Parker fitting
21	CV3192 PKP10TS8BULK	Compression nut, 3/4" FNPT, for drain elbow Insert, for 5/8" OD poly tube
22	CV3158-02	Elbow, Drain, 3/4" Male
23	CV3159-01	Retainer, Drain Line Flow Control
24	CV3162-027 CV3162-032 CV3162-053	Drain Line Flow Control Button: Flow Control Washer, 2.7 GPM (SCT1-30) Flow Control Washer, 3.2 GPM (SCT1-45) Flow Control Washer, 5.3 GPM (SCT1-60, SCT1-75)

Installation Fitting Assemblies

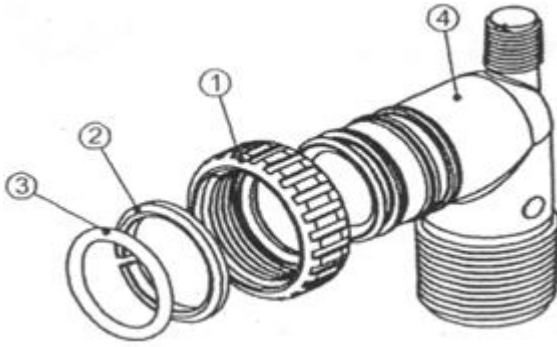

1" PVC MALE NPT ELBOW			
Ref	Part #	Description	Qty
	CV3007	1" PVC male NPT elbow assy	2
1	CV3151	Nut, 1" quick connect	2
2	CV3150	Split ring	2
3	CV3105	O-ring 215	2
4	CV3149	Fitting	2

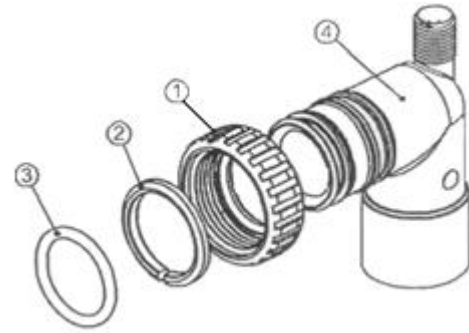

3/4" & 1" PVC SOLVENT ELBOW			
Ref	Part #	Description	Qty
	CV3007-01	3/4" & 1" PVC solvent elbow assy	2
1	CV3151	Nut, 1" quick connect	2
2	CV3150	Split ring	2
3	CV3105	O-ring 215	2
4	CV3189	Fitting	2

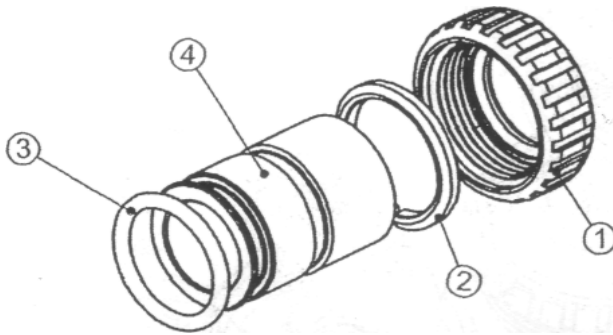

1" BRASS SWEAT			
Ref	Part #	Description	Qty
	CV3007-02	1" brass sweat assembly	2
1	CV3151	Nut, 1" quick connect	2
2	CV3150	Split ring	2
3	CV3105	O-ring 215	2
4	CV3188	Fitting	2

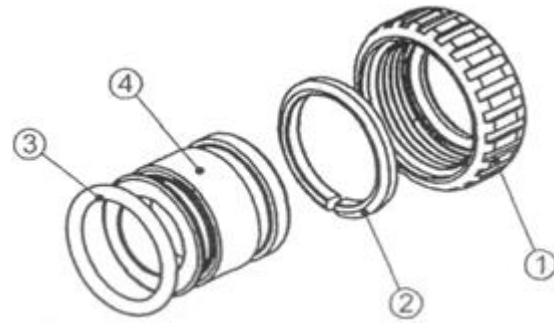

3/4" BRASS SWEAT			
Ref	Part #	Description	Qty
	CV3007-03	3/4" brass sweat assembly	2
1	CV3151	Nut, 1" quick connect	2
2	CV3150	Split ring	2
3	CV3105	O-ring 215	2
4	CV3188-01	Fitting	2

Installation Fitting Assemblies (cont.)

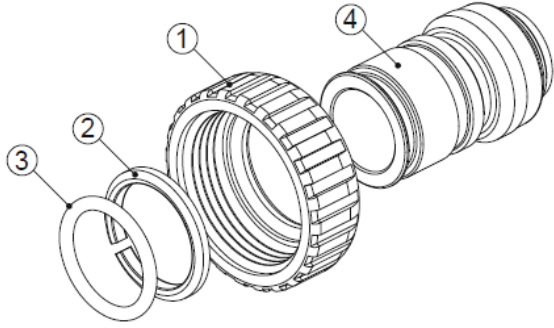

3/4" BRASS SHARK BITE			
Ref	Part #	Description	Qty
	CV3007-12	3/4" brass shark bite assembly	2
1	CV3151	Nut, 1" quick connect	2
2	CV3150	Split ring	2
3	CV3105	O-ring 215	2
4	CV3628	Fitting	2

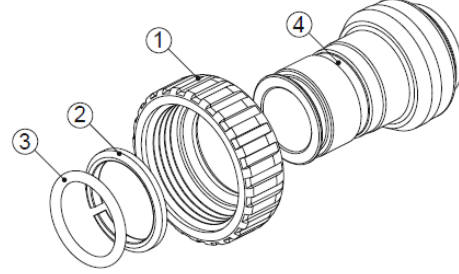

1" BRASS SHARK BITE			
Ref	Part #	Description	Qty
	CV3007-13	1" brass shark bite assembly	2
1	CV3151	Nut, 1" quick connect	2
2	CV3150	Split ring	2
3	CV3105	O-ring 215	2
4	CV3629	Fitting	2

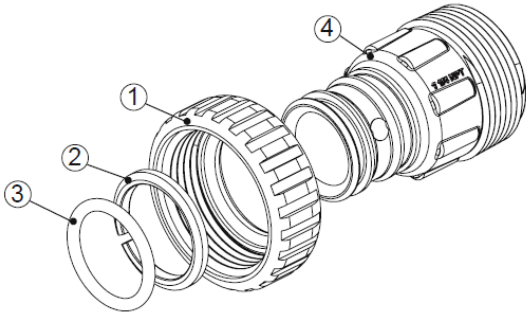

1-1/4" PLASTIC MALE NPT			
Ref	Part #	Description	Qty
	CV3007-04	1-1/4" plastic male NPT assembly	2
1	CV3151	Nut, 1" quick connect	2
2	CV3150	Split ring	2
3	CV3105	O-ring 215	2
4	CV3317	Fitting	2

Installation Fitting Assemblies



3/4" QUICK CONNECT			
Ref	Part #	Description	Qty
K	QFNCR4	3/4" QUICK CONNECT	1*

(*2 required)

SERVICE WRENCH - CV3193

Although no tools are necessary to assemble or disassemble the valve, the *Service Wrench*, (shown in various positions on the valve) is available to aid in assembly or disassembly.

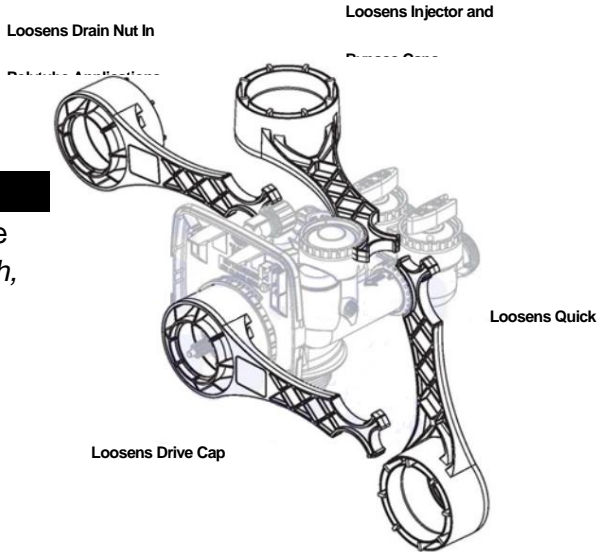

TEN YEAR LIMITED WARRANTY

WARRANTY – Franklin Water Treatment, LLC warrants this water conditioner against any defects that are due to faulty material or workmanship during the warranty period. This warranty does not include damage to the product resulting from accident, neglect, misuse, misapplication, alteration, installation, or operation contrary to printed instructions, or damage caused by freezing, fire, flood, or Acts of God. From the original date of consumer purchase, we will repair or replace, at our discretion, any part found to be defective within the warranty period described below. Purchaser is responsible for any shipping cost to our facility and any local labor charges.

- One year on the entire water conditioner
- Five years on the control valve
(except the seal & spacer kit - 1 year)
- Five years on the brine tank
- Ten years on the mineral tank

GENERAL CONDITIONS – Should a defect or malfunction occur, contact the dealer that you purchased the product from. If you are unable to contact the dealer, contact Franklin Water Treatment, LLC @ (260)693-1972. We will require a full description of the problem, model number, date of purchase, and selling dealer’s business name and address.

We assume no warranty liability in connection with this water conditioner other than specified herein. This warranty is in lieu of all other warranties, expressed or implied, including warranties of fitness for a particular purpose. We do not authorize any person or representative to assume for us any other obligations on the sale of this water conditioner.

FILL IN AND KEEP FOR YOUR RECORDS

Original Purchaser	Date of Purchase	Model #	
Address of Original Installation		City	State
Dealer Purchased From	Dealer Address	City	State

**Franklin Water Treatment, LLC
12630 U.S. 33 North, Churubusco, IN 46723
Phone: (260)693-1972 Fax: (260)693-0602**