

# Installation Instructions and Owner's Manual

## SWS1 Series Water Softening System



---

---

### Franklin Water Treatment, LLC.

12630 US Highway 33 N  
Churubusco, IN 46723

Phone (260) 693-1972

Fax (260) 693-0602

# Table of Contents

<b>Pre-installation Instructions</b>	<b>Page 3</b>
<b>Detailed Installation</b>	<b>Page 5</b>
<b>Brine Tank Components</b>	<b>Page 6</b>
<b>Bypass Valve Operation</b>	<b>Page 7</b>
<b>General Operation &amp; Set Time of Day</b>	<b>Page 8</b>
<b>Installer Settings &amp; Regeneration Display</b>	<b>Page 9</b>
<b>Manual Regeneration</b>	<b>Page 10</b>
<b>Specifications</b>	<b>Page 11</b>
<b>Component Parts Breakdown &amp; List</b>	<b>Page 12</b>
<b>Control Valve Exploded Parts Diagram</b>	<b>Page 13</b>
<b>Control Valve Parts List</b>	<b>Page 14</b>
<b>Installation Fitting Assemblies</b>	<b>Page 15</b>
<b>Troubleshooting</b>	<b>Page 18</b>
<b>Ten Year Limited Warranty</b>	<b>Page 21</b>

This page intentionally left blank

# Pre-installation Instructions

## Description of the water softener system

This water softener system includes a brine (salt) tank and a resin (media) tank with a backwashing control valve. Incoming water flows into the control valve and is directed down through the ion exchange softening resin. This resin exchanges the hardness ions for softer ions. The softened water then returns to the control valve where it is directed into the service lines.

Periodically the control valve will go through a regeneration cycle. The frequency of this regeneration process will depend on the size of water softener, incoming water quality and amount of water used. This cycle is factory preset to begin at 2:00 A.M. At this time the control valve will backwash, draw the brine solution out of the salt tank and flush both the accumulated hardness and excess salt to the drain, followed by a rinse. Prior to the next regeneration cycle the softener will put water back into the brine tank and allow it to dissolve salt for the regeneration.

## Water Quality

The water should be tested to determine the concentration, or levels of the items listed below:

**Hardness** - Hardness in drinking water is defined as those minerals that dissolve in water having a positive electrical charge (cat ions). The primary components of hardness are calcium ( $\text{Ca}^{++}$ ) and magnesium ( $\text{Mg}^{++}$ ) ions. But dissolved iron ( $\text{Fe}^{++}$ ) and manganese ( $\text{Mn}^{++}$ ) also contribute to total "adjusted" hardness. Hardness produces scale, soap scum and white mineral deposits which shorten the life of water using appliances, plumbing and fixtures. Water that has less than 1 grain of hardness is considered "soft" water.

**pH** - A measurement of the acidity of the water. pH is reported on a scale from 0 to 14. Neutral water has a pH of 7.0, lower values indicate acidic water. If your pH is below 6.8 you may consider installing an acid neutralizer before the water softener to elevate the pH.

**Iron** - A naturally occurring metallic element. Iron levels in excess of 0.3 milligrams/liter (mg/l) combine with oxygen causing orange or red (rust) stains on plumbing fixtures. Iron exists in some water sources in clear water (ferrous) state, red water (ferric) state or bacterial form. Iron levels that exceed 2.0 mg/l require special ion exchange resin for reduction, or if bacterial or ferric (red water) iron is present or iron level exceeds 3.0 mg/l, an iron filter should be installed ahead of this water softener.

**Manganese** - A naturally occurring metallic element. Manganese levels as low as 0.05 milligrams/liter (mg/l) can combine with oxygen to cause dark brown or black staining on fixtures. Additionally, manganese can cause an odor in the water similar to a "rotten egg" smell. This water softener may reduce manganese as well as iron; however, an iron filter may be required in some cases.

**Tannin** - A naturally occurring humic acid. Tannin is caused by water passing through decaying vegetation. Coffee and Tea are prime examples of tannin in water. Tannin levels as low as 0.5 milligrams per liter can cause a yellow discoloration in water. Consult your dealer for a system designed to remove both tannin and hardness.

**Hydrogen Sulfide** - A naturally occurring gas. Hydrogen sulfide, more commonly referred to as sulfur gas, causes a distinct odor similar to "rotten eggs." Due to its gaseous nature, hydrogen sulfide must be tested at the well site within 1 minute of drawing the sample. If sulfur is present additional equipment will be required. Air injection iron filters can typically treat up to 2 ppm of sulfur gas if regenerated daily. Specialized filter media may reduce sulfur up to 6 ppm. Beyond 6 ppm and up to 10 ppm require chemical injection. Beyond 10 ppm may be impractical to treat.

# Pre-installation Instructions (cont.)

## Location Considerations

The proper location to install the water softener system will ensure optimum performance and satisfactory water quality. The following factors should be considered in selecting the location of the equipment.

1. The water softener should be installed after the pressure tank on a private well system or after the water meter on municipal water. Operating pressure of the softener must be limited to within 30 – 100 psi range.
2. The water softener should be installed as close as possible (preferably within 15') to an adequate floor or laundry drain capable of handling the backwash cycle volume and flow rate (refer to unit specifications).
3. All water conditioning equipment should be installed prior to the water heater. Water temperatures exceeding 100°F can damage the internal components of the control valve and filter tank. Install with at least 10' of pipe before the water heater to prevent thermal damage to the equipment. An expansion tank may need to be installed in the line to the water heater to allow for thermal expansion and comply with local plumbing codes.
4. The water softener should not be subject to freezing temperatures.
5. Ensure that any cartridge or in-line type filter installed prior to the water softener does not restrict the water flow and pressure available for backwash and interfere with normal operation.
6. Appliances requiring extended periods of continuous or high flow water use (i.e. geothermal heat pumps, swimming pools, lawn irrigation, outside hose bibs, etc.) should bypass the water softener. (see installation diagram Fig. 1).

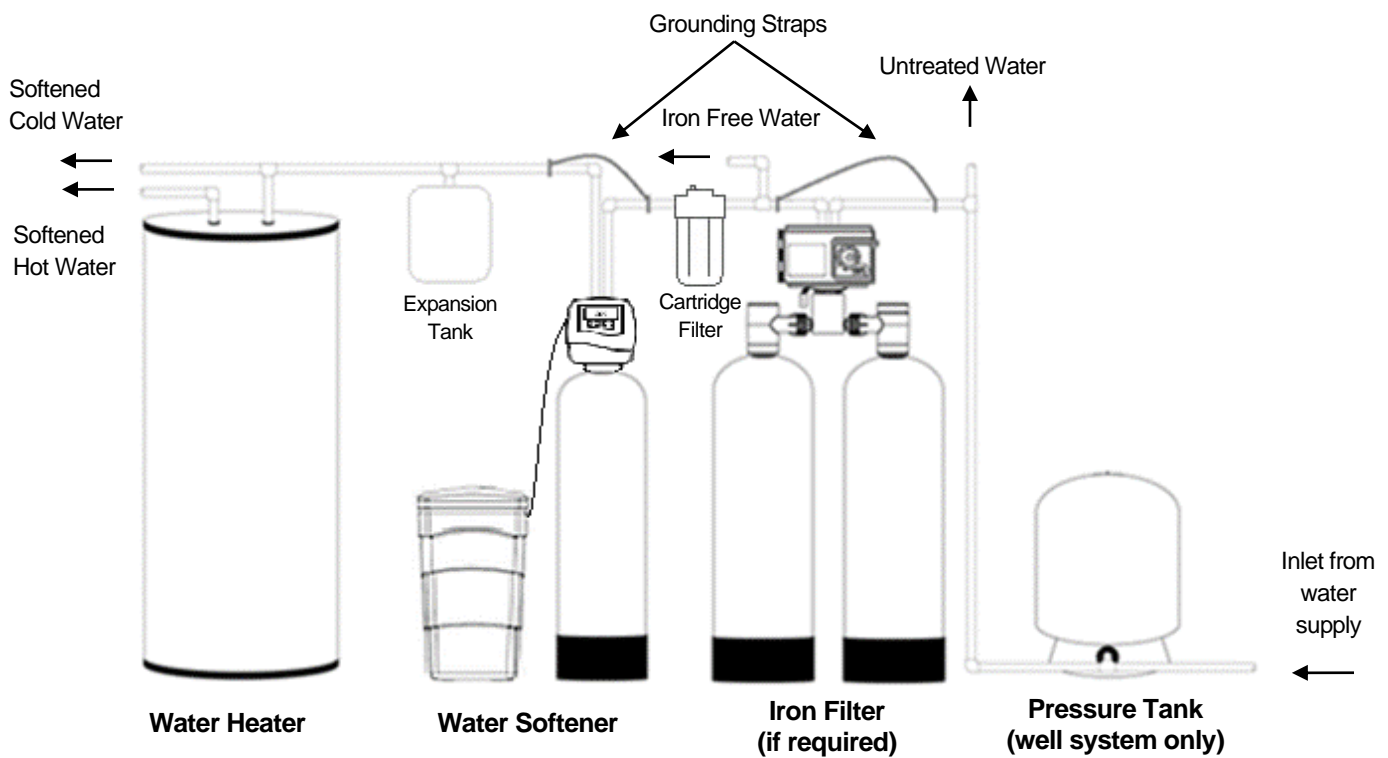

**FIGURE 1: Typical Installation**

# Detailed Installation Instructions

- STEP 1:** Carefully remove all components from packaging. DO NOT DISCARD PACKAGING until all water softener components and fittings have been located.
- STEP 2:** Using the integrated coupling nuts, attach the bypass valve to the inlet/outlet of the control valve and put handles in the bypass position (Figure 2).
- STEP 3:** Place unit at desired installation position.
- STEP 4:** Shut off water at main supply. Relieve pressure by opening nearest faucet. On private well systems, turn off power to pump and drain pressure tank. SHUT OFF POWER OR FUEL SUPPLY TO WATER HEATER.
- STEP 5:** Cut main supply line as required to fit plumbing to inlet and outlet of bypass valve. DO NOT PLUMB INLET AND OUTLET BACKWARDS. Piping should be supported. Do not apply heat to any fitting attached to the bypass or control valve.
- STEP 6:** Use the provided polyethylene tubing (**NO VINYL TUBING**) to run drain line from control valve drain fitting (Figure 2) to floor drain or sump pit capable of handling the backwash rate of the softener (refer to specifications on Page 11). **THE DISCHARGE END OF THE DRAIN LINE MUST BE FIRMLY SECURED!** There must be an air gap at the end of the drain line to prevent siphoning of wastewater and meet plumbing code. Total length of drain line should be 15' or less. AVOID OVERHEAD DRAINS.

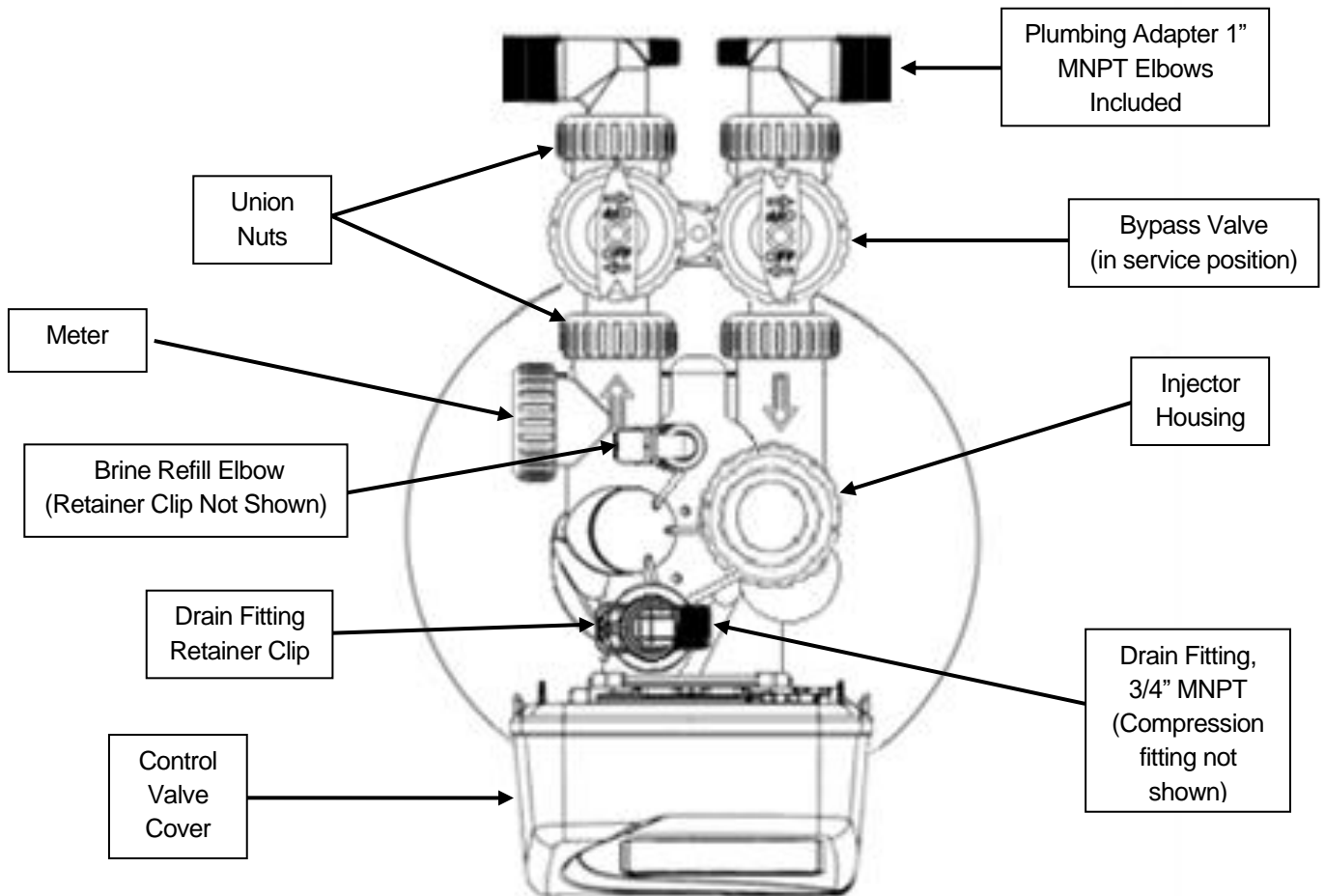

**FIGURE 2: Top View of Control Valve**

## Detailed Installation Instructions (continued)

- STEP 7:** Connect one end of the 3/8" brine line to the control valve quick connect brine refill elbow (Figure 2, Page 5). Insert the other end of the brine line through the hole in the brine tank and into the quick connect fitting on the top of the safety brine valve (Figure 3). Remove the quick connect collet retainer clip (if included) before inserting the brine line into each fitting, press the tube in very firmly and replace the retainer clip behind the collet. **NOTE: THE BRINE TUBING SHOULD BE INSERTED 5/8" INTO THE FITTING. DO NOT PUT SALT INTO THE BRINE TANK AT THIS TIME.**

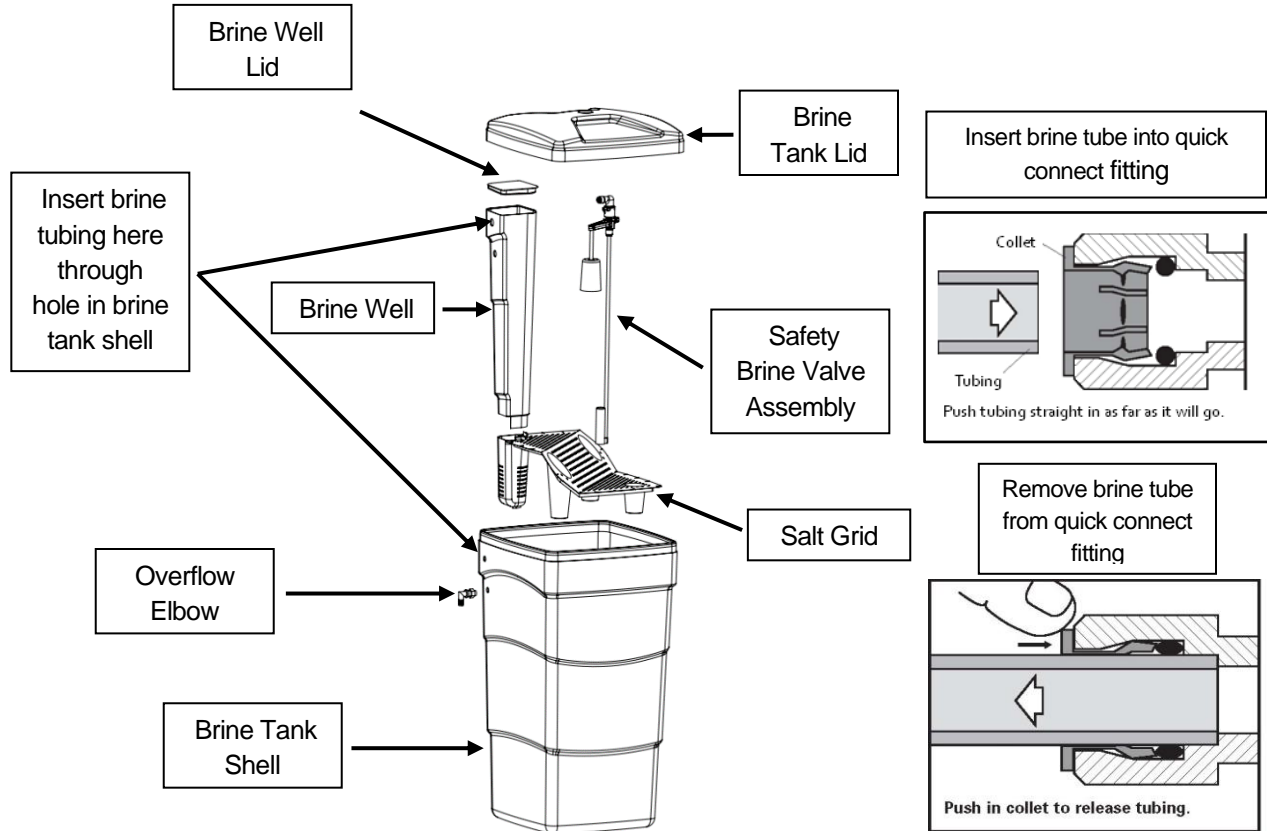

**FIGURE 3: Brine Tank Components**

- STEP 8:** If desired, install overflow tubing (not provided) from overflow elbow on brine tank (Figure 3) to floor drain. Tubing must be lower than the overflow elbow at all times. **DO NOT CONNECT DRAIN LINE FROM SOFTENER CONTROL VALVE TO BRINE TANK OVERFLOW. DO NOT CONNECT BRINE TANK DRAIN LINE TO THE SOFTENER DRAIN LINE.**
- STEP 9:** Plug the transformer into an un-switched electrical outlet. Ensure the control valve is in "Service" mode (time of day is displayed on the screen {refer to page 8 for Home Screen Display}).
- STEP 10:** Place the bypass valve in the "Service" position (refer to Figure 2, Page 5; Figure 4, Page 7) and open main supply valve or turn on power to pump on private well systems. Allow the unit to fill with water and pressurize, then place the bypass valve in the "Bypass" position.
- STEP 11:** Add water in the brine tank to slightly above the top level of the salt grid (approx. 6 gallons). **DO NOT ADD SALT TO THE BRINE TANK AT THIS TIME.**

## Detailed Installation Instructions (continued)

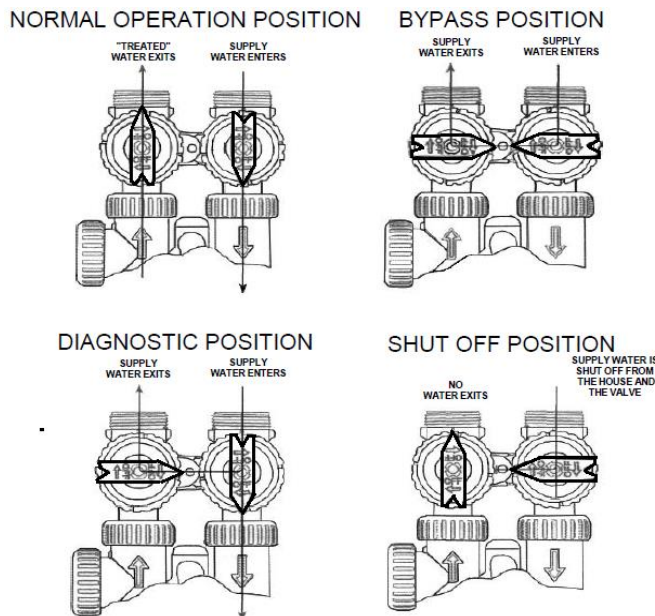

**FIGURE 4: Bypass Valve Operation**

- STEP 12:** With the bypass valve in the “Bypass” position (refer to Figure 2, Page 5; Figure 4, Page 7), press and hold the REGEN button until the motor starts. Then use the REGEN button to advance the control valve to the BACKWASH cycle (refer to page 10 for details) to release pressure and purge air from the mineral tank.
- STEP 13:** Refer to Figure 4 bypass valve operation. Rotate the INLET knob of the bypass valve slowly to the “Service” position. If any air spurts or any softener resin is expelled to the drain, stop turning the knob until only water flows to the drain, then continue turning the knob fully to the “Service” position.
- STEP 14:** When all air has been purged from the system and only water is running to the drain, turn the OUTLET knob of the bypass valve to the “Service” position also. Allow the system to backwash for a few minutes or until the drain water runs clear.
- STEP 15:** Using the REGEN button, advance the control valve to the BRINE DN (downflow brine draw) cycle. Verify that the water level in the brine tank is slowly dropping (less than ½ gpm). Allow water level to drop below the top of the salt grid before continuing. If the water level does not drop, refer to page 18 for Troubleshooting. After verifying water level is dropping advance the control valve past the BACKWASH 2, RINSE AND 5 second FILL cycle to the time of day, using the REGEN button.
- ADD SALT TO BRINE TANK NOW.** Any type of water softener salt may be used.
- STEP 16:** Check for leaks and correct as necessary.
- STEP 17:** Turn power or fuel supply back on to water heater.
- STEP 18:** Press and hold the NEXT and UP buttons together until the screen changes to input the adjusted hardness level water (refer to Installer Settings, Page 9, for details), then press NEXT repeatedly until the time of day is displayed.
- STEP 19:** Press the CLOCK button to set the current time of day. (Page 8, note AM and PM).

# General Operation

When the system is operating one of two displays will be shown. Pressing NEXT will alternate between the displays. One of the displays is always the current time of day. The second display is gallons remaining. This is the number of gallons that can be treated before the system needs to go through a regeneration cycle.

The user can scroll between the displays as desired. If the system has called for a regeneration that will occur at the preset time of regeneration, the words "REGEN TODAY" will appear on the display.

When water is being treated (i.e. water is flowing through the system) the word "SOFTENING" flashes on the display.

REGEN TODAY will show if a regeneration is expected "Tonight."

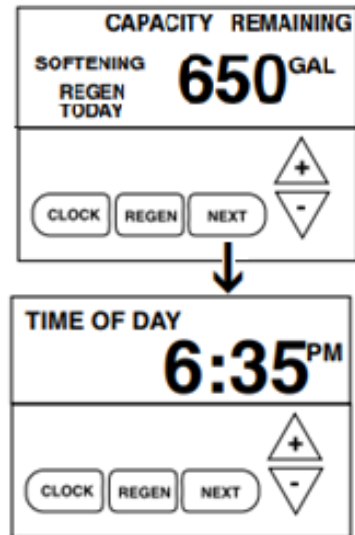

# Set Time of Day

**Step 1** - Press **CLOCK**.

**Step 2** - Current Time (hour): Set the hour of the day using ▲ or ▼ buttons. AM/ PM toggles after 12. Press **NEXT** to go to step 3.

**Step 3** - Current Time (minutes): Set the minutes of day using ▲ or ▼ buttons. Press **NEXT** to exit Clock. Press **REGEN** to return to previous step.

**Power Loss** - Lithium battery on circuit board provides up to 8 hours of time clock backup during power outages. After 8 hours, only the time of day needs to be reset, all other values are stored in non-volatile memory. If a power loss last less than 8 hours and time of day is flashing, replace coin type 2032 battery. Do not forget to reset for daylight savings time

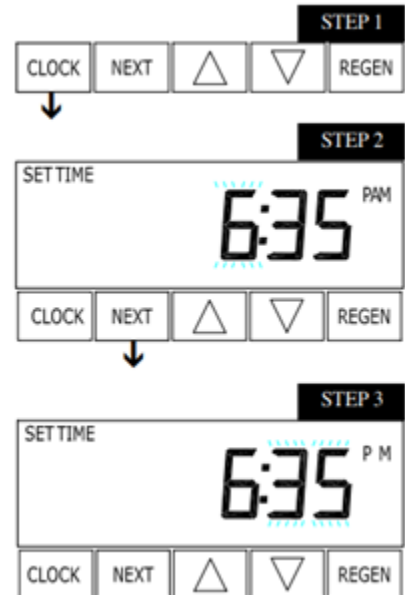

# Installer Settings

**Step 1** - Press **NEXT** and **▲** simultaneously for 3 seconds.

**Step 2 - Hardness:** Set the amount of adjusted hardness in grains per gallon (hardness gpg + (iron ppm x 3) + (manganese ppm x 5)) using **▲** or **▼** buttons. The default is 20 with value ranges from 1 to 150 in 1 grain increments. If this display shows “nA –“, then system is either set-up in “time clock” or “filter” modes. Press **NEXT** to go to Step 3. Press **REGEN** to exit Installer Settings.

**Step 3 - Day Override:** This sets the maximum number of days between regenerations. If value set to “OFF” regeneration is initiated automatically solely on gallons used. If value is set as a number (allowable range from 1 to 28) a regeneration will be initiated automatically on that day even if metered gallon usage does not trigger a regeneration. Press **NEXT** to go to step 4. Press **REGEN** to return to previous step.

**Step 4 - Regeneration Time (hour):** Set the hour of day for regeneration using **▲** or **▼** buttons. AM/PM toggles after 12. The default time is 2:00 a.m. This display will show “REGEN” on 0 GAL if system is set for immediate regeneration. Press **NEXT** to go to step 5. Press **REGEN** to return to previous step.

**Step 5 - Regeneration Time (minutes):** Set the minutes for the regeneration time using **▲** or **▼** buttons. This display will not be shown if system is set for immediate regeneration. Press **NEXT** to exit Installer Displays/Settings. Press **REGEN** to return to previous step.



# Regeneration Display

Typically, a system is set to regenerate at a time of low water usage. An example of a time with low water usage is when the household is asleep. If there is a demand for water when the system is regenerating, untreated water will be supplied. When the system begins to regenerate, the display will change to include information about the step of the regeneration process and the time remaining for that step to be completed. The system runs through the steps automatically and will reset itself to provide treated water when the regeneration has been completed.

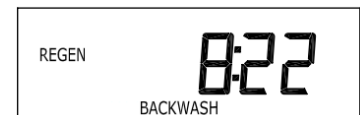

# Manual Regeneration

Sometimes there is a need to regenerate the system, sooner than when the system calls for it, usually referred to as manual regeneration. There may be a period of heavy water usage because of guests or a heavy laundry day.

**To initiate a manual regeneration at the preset delayed regeneration time**, press and release **REGEN**. The words "REGEN TODAY" will flash on the display to indicate that the system will regenerate at the preset delayed regeneration time. If you pressed the **REGEN** button in error, pressing the button again will cancel the request.

**To initiate a manual regeneration immediately**, press and hold the **REGEN** button for three seconds. The system will begin to regenerate immediately. The request cannot be cancelled. You must cycle all the way through the cycles to make it stop. PLEASE NOTE: This will reset the meter. If back-to-back regenerations are desired, press and release **REGEN** button. "REGEN TODAY" will appear on screen. Push and hold **REGEN** button to initiate immediate regeneration. The softener will regenerate again at specified time. Back-to-back regenerations are recommended when salt is allowed to run out in brine tank. Note: If the brine tank does not contain salt, fill with salt and wait at least 90 minutes before regenerating



# Specifications

Description	Two Tank Models				Cabinet Models		Space Saver Model
	SWS1-0948	SWS1-1054	SWS1-1248	SWS1-1354	SCCWS1-1035	SCCWS1-1044	SWS1C-1035
<b>Resin Volume ft<sup>3</sup></b>	1.0	1.5	2.0	2.5	1.0	1.3	1.0
<b>Capacity, grains</b>							
@Factory Salt	24,000	36,000	48,000	60,000	24,000	32,000	24,000
@Max. Salt @ 15lb/ft <sup>3</sup>	30,000	45,000	60,000	75,000	30,000	39,000	30,000
<b>Gravel Underbed, lbs</b>	15	20	25	30	20	20	20
<b>Operating Flow Rate, gpm</b>							
Continuous (3 gpm/ft <sup>3</sup> )	3	5	5	8	3	4	3
Service (<=8 gpm/ft <sup>3</sup> , <15psi drop)	8	12	14	18	8	10	8
Peak (<20 psi drop)	18	18	23	22	22	19	22
<b>Regen. Flow Rates, gpm</b>							
Backwash & Rapid Rinse	2.2	2.7	3.2	4.2	2.7	2.7	2.7
Injector	Blue	Blue	Blue	Yellow	Blue	Blue	Blue
Brine Draw - Rinse (@ 50 psi)	0.38-0.5	0.38-0.5	0.38-0.5	0.43-0.64	0.38-0.5	0.38-0.5	0.38-0.5
<b>Service Pipe Size, in.</b>	1"	1"	1"	1"	1"	1"	1"
<b>Factory Regeneration Settings</b>							
Brine Tank Fill (lbs of salt)	9	13.5	18	22.5	9	12	9
Softening (minutes dissolving salt)	120	120	120	120	120	120	120
P Code	P7	P11	P12	P12	P7	P7	P7
Backwash (minutes)	6	7	7	7	6	6	6
Brine Draw & Rinse (minutes)	45	60	65	65	45	45	45
Backwash 2 (minutes)	4	6	7	7	4	4	4
Rapid Rinse (minutes)	3	6	7	7	3	3	3
<b>Total Water Used, gallons</b>	53	84	104	133	60	61	60
<b>Dimensions (inches)</b>							
Mineral Tank, diameter x height	9x48	10x54	12x48	13x54	10x35	10x44	10x35
Brine Tank, width x depth x height	18x18x33	18x18x33	18x18x33	18x18x33	-NA-	-NA-	12X12X34
Overall, depth x width x height:	18x27x56	18x28x62	18x30x56	18x31x62	12x24x45	12x24x50	16x23x43
<b>Approximate Ship Wt., lbs.</b>	104	137	162	213	105	135	94

Description	HE Two Tank Models				HE Space Saver Model
	SWS1-1035-HE	SWS1-1054-HE	SWS1-1248-HE	SWS1-1354-HE	SWS1C-1035-HE
<b>Resin Volume ft<sup>3</sup></b>	1.0	1.5	2.0	2.5	1.0
<b>Capacity, grains</b>					
@Factory Salt	22,000	33,000	44,000	55,000	22,000
@Max. Salt @ 15lb/ft <sup>3</sup>	31,000	46,500	62,000	77,500	31,000
<b>Gravel Underbed, lbs</b>	15	20	25	30	20
<b>Operating Flow Rate, gpm</b>					
Continuous (3 gpm/ft <sup>3</sup> )	3	5	5	8	3
Service (<=8 gpm/ft <sup>3</sup> , <15 psi drop)	8	12	14	18	8
Peak (<20 psi drop)	18	18	23	22	22
<b>Regen. Flow Rates, gpm</b>					
Backwash & Rapid Rinse	2.2	2.7	3.2	4.2	2.7
Injector	Blue	Blue	Blue	Yellow	Blue
Brine Draw / Rinse (@ 50 psi)	0.38-0.5	0.38-0.5	0.38-0.5	0.43-0.64	0.38-0.5
<b>Service Pipe Size, in.</b>	1"	1"	1"	1"	3/4" & 1"
<b>Factory Regeneration Settings</b>					
Brine Tank Fill (lbs of salt)	6	9	12	15	6
Softening (minutes dissolving salt)	120	120	120	120	120
P Code	P3	P8	P8	P8	P3
Backwash (minutes)	4	6	6	6	4
Brine Draw & Rinse (minutes)	45	60	60	60	45
Backwash 2 (minutes)	4	5	5	5	4
Rapid Rinse (minutes)	3	4	4	4	3
<b>Total Water Used, gallons</b>	48	72	81	104	53
<b>Dimensions (inches)</b>					
Mineral Tank, diameter x height	9x48	10x54	12x48	13x54	10x35
Brine Tank, width x depth x height	18x18x33	18x18x33	18x18x33	18x18x33	12X12X34
Overall, depth x width x height:	18x27x56	18x28x62	18x30x56	18x31x62	16x23x43
<b>Approximate Ship Wt., lbs.</b>	104	137	162	213	94

# Component Parts Breakdown

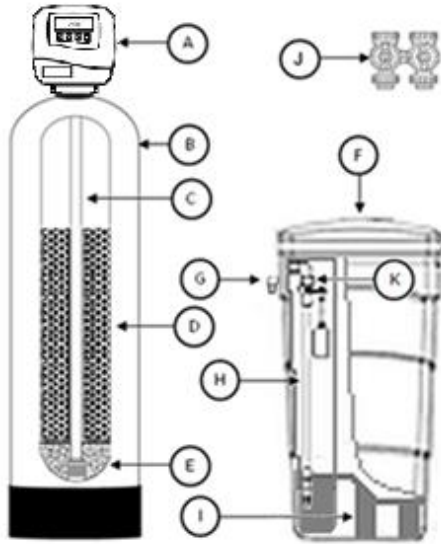

Ref	Description	Two Tank Models				Cabinet Models Cabinet Model		Space Saver Model
		SWS1-0948	SWS1-1054	SWS1-1248	SWS1-1354	SCCWS1-1035	SCCWS1-1044	SWS1C-1035
A	Control Valve L/ bypass	SWS1-0948-VLV- ASSY- L-BP	SWS1-1054-VLV- ASSY- L-BP	SWS1-1248-VLV- ASSY- L-BP	SWS1-1354-VLV- ASSY- L-BP	SCCWS1-1035- VLV-ASSY-L-BP	SCCWS1-1044- VLV-ASSY-L-BP	SWS1C-1035- VLV-ASSY-L-BP
B	Mineral Tank	MTP0948GR	MTP1054GR	MTP1248GR	MTP1354GR	MTP1035GR	MTP1044GR	MTP1035GR
C	Distributor	D100S-48	D100S-54	D100S-48	D100S-54	D100S-48	D100S-48	D100S-48
D	Resin	Qty 2 - H05P	Qty 3 - H05P	Qty 4 - H05P	Qty 5 - H05P	Qty 2 - H05P	Qty 2.5 - H05P	Qty 2 - H05P
E	1/4" X 1/8" Gravel	Qty 1 - QC20	Qty 1 - QC20	Qty 1 - QC20	Qty 1-1/2 - QC20	Qty 1 - QC20	Qty 1 - QC20	Qty 1 - QC20
F	Brine Tank Assy.	BTSQ1833ASSY	BTSQ1833ASSY	BTSQ1833ASSY	BTSQ1833ASSY	BC-1035C	BC-1044C	BT1234ASSY
G	Overflow Fitting	BT-OVERFLO	BT-OVERFLO	BT-OVERFLO	BT-OVERFLO	BT-OVERFLO	BT-OVERFLO	BT-OVERFLO
H	Safety Brine Viv.	SBV14ASSY	SBV14ASSY	SBV14ASSY	SBV14ASSY	SBV14ASSY	SBV14ASSY	SBV14ASSY
I	Salt Platform	BTSG18SQ	BTSG18SQ	BTSG18SQ	BTSG18SQ	-NA-	-NA-	BTSG12
J	Bypass (L/Adapters)	CV3006	CV3006	CV3006	CV3006	CV3006	CV3006	CV3006
K	Elbow Locking Clip	FC103	FC103	FC103	FC103	FC103	FC103	FC103
-NA-	Top Screen	-NA-	-NA-	-NA-	-NA-	18280-02	18280-02	18280-02

Ref	Description	HE Two Tank Models				HE Space Saver Model
		SWS1-0948-HE	SWS1-1054-HE	SWS1-1248-HE	SWS1-1354-HE	SWS1C-1035-HE
A	Control Valve L/ bypass	SWS1-0948-HE- VLV-ASSY- L-BP	SWS1-1054-HE- VLV-ASSY- L-BP	SWS1-1248-HE- VLV-ASSY- L-BP	SWS1-1354-VLV- ASSY- L-BP	SWS1C-1035-HE- VLV-ASSY-L-BP
B	Mineral Tank	MTP0948GR	MTP1054GR	MTP1248GR	MTP1354GR	MTP1035GR
C	Distributor	D100S-48	D100S-54	D100S-48	D100S-54	D100S-48
D	Resin	Qty 2 - UHE05P	Qty 3 - UHE05P	Qty 4 - UHE05P	Qty 5 - UHE05P	Qty 2 - UHE05P
E	1/4" X 1/8" Gravel	Qty 1 - QC20	Qty 1 - QC20	Qty 1 - QC20	Qty 1-1/2 - QC20	Qty 1 - QC20
F	Brine Tank Assy.	BTSQ1833ASSY	BTSQ1833ASSY	BTSQ1833ASSY	BTSQ1833ASSY	BT1234ASSY
G	Overflow Fitting	BT-OVERFLO	BT-OVERFLO	BT-OVERFLO	BT-OVERFLO	BT-OVERFLO
H	Safety Brine Viv.	SBV14ASSY	SBV14ASSY	SBV14ASSY	SBV14ASSY	SBV14ASSY
I	Salt Platform	BTSG18SQ	BTSG18SQ	BTSG18SQ	BTSG18SQ	BTSG12
J	Bypass (L/Adapters)	CV3006	CV3006	CV3006	CV3006	CV3006
K	Elbow Locking Clip	FC103	FC103	FC103	FC103	FC103
-NA-	Top Screen	18280-02	18280-02	18280-02	18280-02	18280-02

See pages 15 - 17 for plumbing adapters, 1" MNPT elbows and 3/4" compression adapters included with unit.

# Control Valve Breakdown

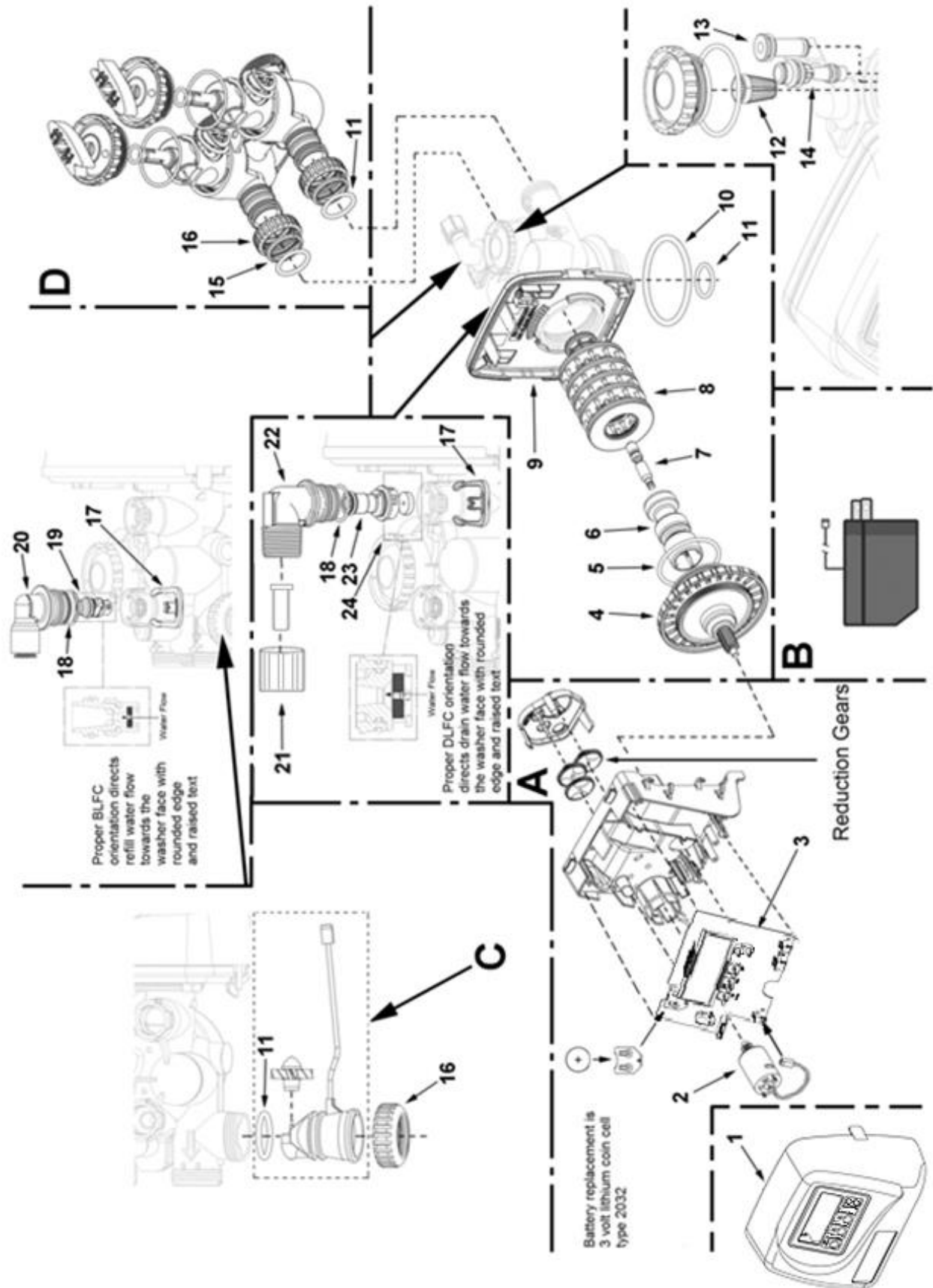

# Control Valve Parts List

REF #	Part Number	Description
A	CV3002SWS1	Drive Assembly, SWS1 Series
B	CV3186-06	Power Cord with Transformer, 15 VDC
C	CV3003	Meter and Cable Assembly
D	CV3006	Bypass Valve, Less Fittings
1	CV3992-01	Front Cover, Black, SWS Series
2	CV3107-01	Drive Motor
3	CV3940HC-01BOARD	Circuit Board, SWS Series
4	CV3004	Drive Cap Assembly
5	CV3135	O-ring, -228
6	CV3011	Piston Assembly
7	CV3174	Brine Valve
8	CV3005	Seal Cartridge Assembly
9	CV3178	Back Plate
10	CV3180	Base O-ring, -337
11	CV3105	O-ring, -215
12	CV3177-01	Injector Screen
13	CV3010-1Z	Plug, Injector Assembly
14	CV3010-1F CV3010-1G	Injector, Blue Injector, Yellow (Only models SWS1-1354 & SWS1-1354-HE)
15	CV3150	Retainer, Split Ring
16	CV3151	Nut, 1" Quick Connect
17	CH4615	Clip, Elbow Locking
18	CV3163	O-ring, -019
19	CV3165-01	Retainer, Brine Refill Flow Control
20	CV4144	3/8" Elbow, Parker fitting
21	CV3192 PKP10TS8BULK	Compression nut, 3/4" FNPT, for drain elbow Insert, for 5/8" OD poly tube
22	CV3158-02	Elbow, Drain, 3/4" Male
23	CV3159-01	Retainer, Drain Line Flow Control
24	CV3162-022 CV3162-027 CV3162-032 CV3162-042	<b>Drain Line Flow Control Button (same for "-HE" models):</b> Flow Control Washer, 2.2 GPM (SWS1-0948) Flow Control Washer, 2.7 GPM (SWS1-1054, *Cabinet & Space Saver) Flow Control Washer, 3.2 GPM (SWS1-1248) Flow Control Washer, 4.2 GPM (SWS1-1354) *Not available with "-HE" suffix

# Installation Fitting Assemblies

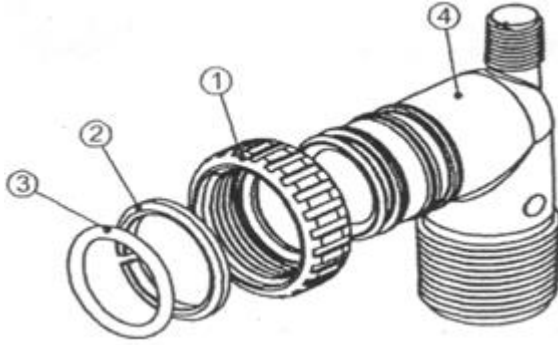

1" PVC MALE NPT ELBOW			
Ref	Part #	Description	Qty
	CV3007	1" PVC male NPT elbow assy	2
1	CV3151	Nut, 1" quick connect	2
2	CV3150	Split ring	2
3	CV3105	O-ring 215	2
4	CV3149	Fitting	2

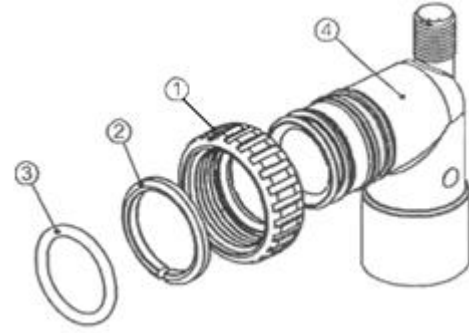

3/4" & 1" PVC SOLVENT ELBOW			
Ref	Part #	Description	Qty
	CV3007-01	3/4" & 1" PVC solvent elbow assy	2
1	CV3151	Nut, 1" quick connect	2
2	CV3150	Split ring	2
3	CV3105	O-ring 215	2
4	CV3189	Fitting	2

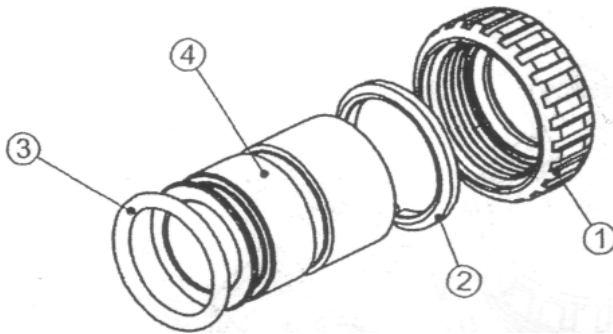

1" BRASS SWEAT			
Ref	Part #	Description	Qty
	CV3007-02	1" brass sweat assembly	2
1	CV3151	Nut, 1" quick connect	2
2	CV3150	Split ring	2
3	CV3105	O-ring 215	2
4	CV3188	Fitting	2

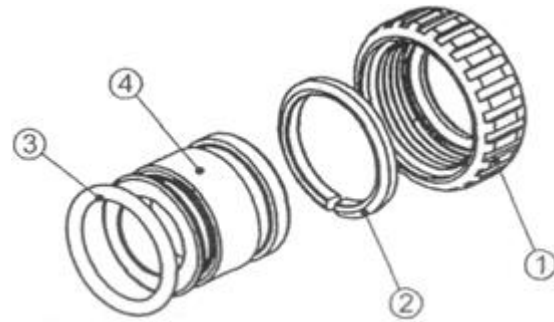

3/4" BRASS SWEAT			
Ref	Part #	Description	Qty
	CV3007-03	3/4" brass sweat assembly	2
1	CV3151	Nut, 1" quick connect	2
2	CV3150	Split ring	2
3	CV3105	O-ring 215	2
4	CV3188-01	Fitting	2

## Installation Fitting Assemblies (cont.)

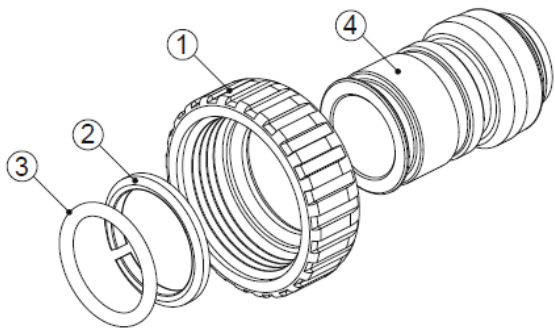

3/4" BRASS SHARK BITE			
Ref	Part #	Description	Qty
	CV3007-12	3/4" brass shark bite assembly	2
1	CV3151	Nut, 1" quick connect	2
2	CV3150	Split ring	2
3	CV3105	O-ring 215	2
4	CV3628	Fitting	2

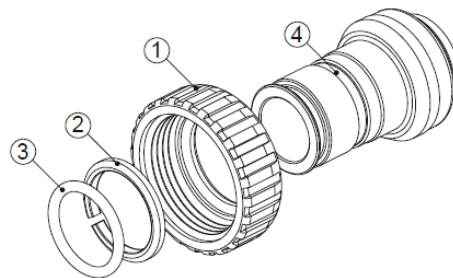

1" BRASS SHARK BITE			
Ref	Part #	Description	Qty
	CV3007-13	1" brass shark bite assembly	2
1	CV3151	Nut, 1" quick connect	2
2	CV3150	Split ring	2
3	CV3105	O-ring 215	2
4	CV3629	Fitting	2

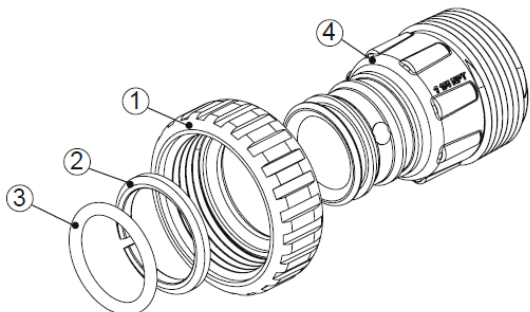

1-1/4" PLASTIC MALE NPT			
Ref	Part #	Description	Qty
	CV3007-05	1-1/4" plastic male NPT assembly	2
1	CV3151	Nut, 1" quick connect	2
2	CV3150	Split ring	2
3	CV3105	O-ring 215	2
4	CV3317	Fitting	2

## Installation Fitting Assemblies (cont.)

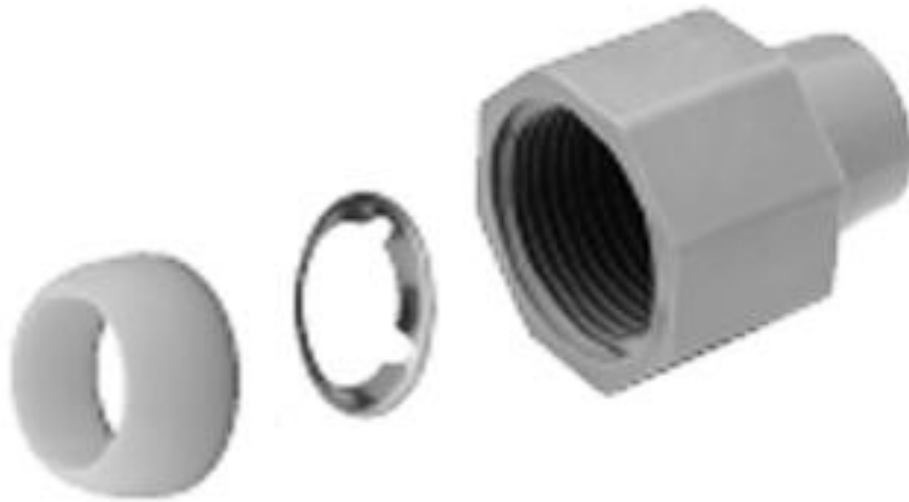

3/4" QUICK CONNECT			
Ref	Part #	Description	Qty
K	QFNCR4	3/4" QUICK CONNECT	1*

(\*2 required)

### SERVICE WRENCH - CV3193

Although no tools are necessary to assemble or disassemble the valve, the *Service Wrench*, (shown in various positions on the valve) is available to aid in assembly or disassembly.

Loosens Drain Nut In Polytube Applications

Loosens Injector and Bypass Caps

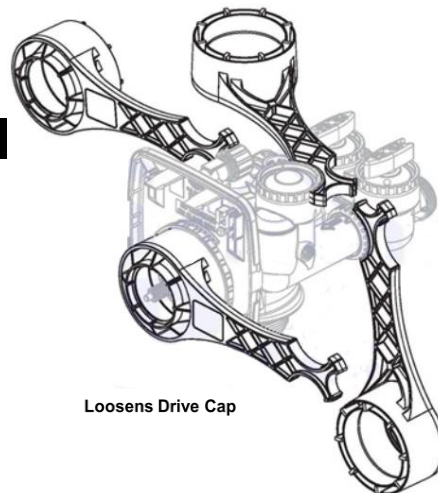

Loosens Quick Connect Nuts

Loosens Drive Cap

# Troubleshooting

PROBLEM	CAUSES	SOLUTIONS
Brine tank overfills or does not draw brine	<ul style="list-style-type: none"> <li>A) Loose nut at either end of the brine line</li> <li>B) Brine line inserted into the brine tank overflow fitting rather than connected to the safety brine valve</li> <li>C) Softener drain line connected to brine overflow fitting or overflow drain line</li> <li>D) Obstruction in the control valve</li> <li>E) Problems with drain line: plugged, frozen, kinked, flexible tubing, overhead installation, diameter too small, longer than 15'</li> <li>F) Missing BLFC</li> <li>G) Missing brine stem</li> <li>H) Dirty brine tank</li> </ul>	<ul style="list-style-type: none"> <li>1) Tighten nuts at either end of brine line</li> <li>2) Verify brine line is installed correctly</li> <li>3) Verify softener drain line is not connected to brine overflow elbow or brine overflow drain line</li> <li>4) Check for debris in DLFC Assembly, BLFC Assembly, injector, injector screen</li> <li>5) Manually put softener into Backwash Cycle (page 7, beginning with step 12) and unplug the transformer for 30 minutes to dislodge debris from inside the control valve or disassemble and clean control valve internal components</li> <li>6) Resolve issues with the drain line</li> <li>7) Verify brine line flow control button is not missing</li> <li>8) Verify piston brine stem is not missing</li> <li>9) Clean out brine tank</li> </ul>
Hard water or softener not using salt	<ul style="list-style-type: none"> <li>A) Softener is plugged into an electrical outlet without power or one that is tied to a switch</li> <li>B) No salt in the brine tank</li> <li>C) Salt in the brine tank has "bridged"</li> <li>D) Bypass Valve is not in "Service" position or is leaking</li> <li>E) Obstruction in control valve</li> <li>I) Problems with drain line: : (See letter "E" in prior section)</li> <li>F) Control valve programmed incorrectly</li> <li>G) Softener sized improperly for actual service flow rates</li> <li>H) Faulty or unplugged drive motor</li> <li>I) Meter cable disconnected</li> </ul>	<ul style="list-style-type: none"> <li>1) Verify softener has uninterrupted power</li> <li>2) Fill brine tank with salt</li> <li>3) Hit the side of the brine tank with rubber mallet to break any bridging that has formed in the brine tank</li> <li>4) Verify bypass is in "Service" position (Figure 4, Page 7)</li> <li>5) Check for debris in DLFC Assembly, BLFC Assembly, injector, injector screen</li> <li>6) Manually put softener into Backwash Cycle (page 7, beginning with step 12) and unplug transformer for 20-30 minutes to dislodge debris</li> <li>7) Resolve issues with drain line</li> <li>8) Review control valve programming</li> <li>9) Verify actual service flow rates required and compare to system specifications (page 11)</li> <li>10) Verify drive motor is connected to control valve circuit board connector J1 (labeled "MOTOR")</li> <li>11) Verify meter cable (grey cable, 3 pins) is connected to control valve circuit board connector J2 (labeled "METER")</li> </ul>

## Troubleshooting (cont.)

PROBLEM	CAUSES	SOLUTIONS
Softener regenerates at wrong time of day	<ul style="list-style-type: none"> <li>A) Clock is not set</li> <li>B) Power outage</li> <li>C) Incorrect control valve programming</li> </ul>	<ul style="list-style-type: none"> <li>1) Reset softener clock (page 8)</li> <li>2) Verify control valve programming (pages 9 &amp; 11)</li> </ul>
Resin in water lines, plugged aerators	<ul style="list-style-type: none"> <li>A) Unit is installed backwards</li> <li>B) Distributor basket is damaged</li> </ul>	<ul style="list-style-type: none"> <li>1) Re-plumb unit with water supply entering bypass inlet (page 5)</li> <li>2) Replace damaged distributor basket</li> </ul>
Salty Water	<ul style="list-style-type: none"> <li>A) Brine tank overfilled</li> <li>B) Problems with drain line: (See Letter "E" in Brine Tank Overfill section)</li> <li>C) Rinse cycle is short</li> <li>D) Salt setting too high</li> <li>E) Distributor tube improperly seated in control valve or is too short</li> <li>F) Low water pressure</li> </ul>	<ul style="list-style-type: none"> <li>1) See "Brine tank overfills" section (Page 18)</li> <li>2) Resolve drain line issues</li> <li>3) Contact technical support for assistance in verifying \ adjusting Rinse Cycle length and Salt Setting</li> <li>4) Verify proper installation of distributor tube</li> <li>5) Verify at least 25 psi of line pressure</li> </ul>
Softener leaks to drain in "Service" position	<ul style="list-style-type: none"> <li>A) Problem in piston cartridge assembly</li> <li>B) Control valve is jammed or halted during regeneration</li> <li>C) Drive cap assembly is not tightened properly</li> </ul>	<ul style="list-style-type: none"> <li>1) Replace seals and/or piston if needed</li> <li>2) Verify control valve is in "SOFTENING" mode</li> <li>3) Tighten drive cap assembly</li> </ul>
Low water pressure	<ul style="list-style-type: none"> <li>A) Iron or sediment build up in softener</li> <li>B) Insufficient pump capacity</li> </ul>	<ul style="list-style-type: none"> <li>1) Increase backwash frequency by increasing hardness setting (page 9)</li> <li>2) Verify at least 25 psi of line pressure</li> </ul>
Display is blank	<ul style="list-style-type: none"> <li>A) Control valve circuit board needs reset</li> <li>B) Transformer is unpowered, unplugged or defective</li> <li>C) Defective circuit board</li> </ul>	<ul style="list-style-type: none"> <li>1) Hold "NEXT" and "REGEN" buttons for 3 seconds</li> <li>2) Remove battery, unplug power for 5 seconds, plug back in, replace dead battery</li> <li>3) Verify transformer is plugged into an electrical outlet that has power and transformer cable (black, 4 pins) is plugged into control valve connector J4 (labeled "POWER")</li> <li>4) With transformer plugged into electrical outlet, use a volt meter to test the 2 outer pins (furthest left and furthest right) of connector J4 on the control valve circuit board. Should be approximately 15 volts DC. Replace transformer if defective.</li> <li>5) Replace circuit board if needed</li> </ul>
"SOFTENING" does not display when water is flowing	<ul style="list-style-type: none"> <li>A) Bypass valve not in "Service" position</li> <li>B) Meter cable disconnected</li> <li>C) Restricted/stalled meter turbine</li> <li>D) Defective meter</li> </ul>	<ul style="list-style-type: none"> <li>1) Verify bypass is in "Service" position (Figure 4, Page 7)</li> <li>2) Verify meter cable (grey cable, 3 pins) is connected to control valve circuit board connector J2 (labeled "METER")</li> <li>3) Remove meter and check for restriction</li> <li>4) Replace meter if needed</li> </ul>

## Troubleshooting (cont.)

PROBLEM	CAUSES	SOLUTIONS
Display shows incorrect time-of-day or time-of-day flashes	<ul style="list-style-type: none"> <li>A) Outlet is on a switch</li> <li>B) Power outage</li> <li>C) Control valve was reset</li> <li>D) Defective circuit board</li> </ul>	<ul style="list-style-type: none"> <li>1) Use an un-switched outlet</li> <li>2) Reset time-of-day</li> <li>3) Replace circuit board if needed</li> </ul>
<b>ERROR CODE:</b>		
<b>1001</b> – unable to sense motor movement	<ul style="list-style-type: none"> <li>A) Drive motor not inserted fully to engage pinion or is defective</li> <li>B) Circuit board not properly snapped into drive bracket</li> <li>C) Center reduction gear reflector dirty</li> </ul>	<ul style="list-style-type: none"> <li>1) Re-insert motor, check for broken wires, verify motor plugged into connector J1 (labeled “MOTOR”) on control valve circuit board and reset control valve (hold “NEXT” and “REGEN” buttons for 3 seconds)</li> <li>2) Re-seat circuit board into drive bracket and reset control valve</li> <li>3) Clean reduction gear reflectors (page 13)</li> </ul>
<b>1002</b> – unexpected motor stall	<ul style="list-style-type: none"> <li>A) Obstruction in control valve</li> <li>B) Main drive gear too tight</li> <li>C) Improper voltage delivered to circuit board</li> </ul>	<ul style="list-style-type: none"> <li>1) Remove piston and seal assemblies for inspection and repair or replacement and reset control valve (hold “NEXT” and “REGEN” buttons for 3 seconds)</li> <li>2) Loosen main drive gear and reset control valve</li> <li>3) Verify proper voltage is being supplied to circuit board (see Solution 4 under “Display is Blank” section, page 19)</li> </ul>
<b>1003</b> – motor ran too long, cannot find next cycle position	<ul style="list-style-type: none"> <li>A) Motor failure during regeneration</li> <li>B) Obstruction in control valve</li> <li>C) Drive bracket not snapped in place properly</li> </ul>	<ul style="list-style-type: none"> <li>1) Re-insert motor, check for broken wires, verify motor plugged into connector J1 (labeled “MOTOR”) on control valve circuit board and reset control valve (hold “NEXT” and “REGEN” buttons for 3 seconds)</li> <li>2) Remove piston and seal assemblies for inspection and repair or replacement and reset control valve</li> <li>3) Re-seat drive bracket assembly and reset control valve</li> </ul>
<b>1004</b> – motor ran too long, timed out trying to reach home position	<ul style="list-style-type: none"> <li>A) Drive bracket not snapped in place properly</li> <li>B) Center reduction gear reflector dirty</li> </ul>	<ul style="list-style-type: none"> <li>1) Re-seat drive bracket assembly and reset control valve (hold “NEXT” and “REGEN” buttons for 3 seconds)</li> <li>2) Clean reduction gear reflectors (page 13)</li> </ul>
<b>1006</b> – MAV/SEPS/NHBP/AUX MAV motor ran too long, looking for park position	<ul style="list-style-type: none"> <li>A) Control valve not programmed for ALT OFF</li> <li>B) Obstruction in control valve</li> </ul>	<ul style="list-style-type: none"> <li>1) Enter cycle programming level and verify second parameter is set to ALT OFF</li> <li>2) Remove piston and seal assemblies for inspection and repair or replacement and reset control valve (hold “NEXT” and “REGEN” buttons for 3 seconds)</li> </ul>
<b>1007</b> – MAV/SEPS/NHBP/AUX MAV motor ran too short looking for park position	<ul style="list-style-type: none"> <li>A) Control valve not programmed for ALT OFF</li> <li>B) Obstruction in control valve</li> </ul>	<ul style="list-style-type: none"> <li>1) Enter cycle programming level and verify second parameter is set to ALT OFF</li> <li>2) Remove piston and seal assemblies for inspection and repair or replacement and reset control valve (hold “NEXT” and “REGEN” buttons for 3 seconds)</li> </ul>

# TEN YEAR LIMITED WARRANTY

**WARRANTY** – Franklin Water Treatment, LLC, warrants this water conditioner against any defects that are due to faulty material or workmanship during the warranty period. This warranty does not include damage to the product resulting from accident, neglect, misuse, misapplication, alteration, installation, or operation contrary to printed instructions, or damage caused by freezing, fire, flood, or Acts of God. From the original date of consumer purchase, we will repair or replace, at our discretion, any part found to be defective within the warranty period described below. Purchaser is responsible for any shipping cost to our facility and any local labor charges.

- One year on the entire water conditioner
- Five years on the control valve  
(except the seal & spacer kit which is a wear & tear component, 1 year)
- Five years on the brine tank (if applicable)
- Ten years on the mineral tank

**GENERAL CONDITIONS** – Should a defect or malfunction occur, contact the dealer that you purchased the product from. If you are unable to contact the dealer, contact Franklin Water Treatment, LLC at (260)693-1972. We will require a full description of the problem, model number, date of purchase, and selling dealer’s business name and address.

We assume no warranty liability in connection with this water conditioner other than specified herein. This warranty is in lieu of all other warranties, expressed or implied, including warranties of fitness for a particular purpose. We do not authorize any person or representative to assume for us any other obligations on the sale of this water conditioner.

**FILL IN AND KEEP FOR YOUR RECORDS**

Original Purchaser	Date of Purchase	Model #	
Address of Original Installation		City	State
Dealer Purchased From	Dealer Address	City	State

Franklin Water Treatment, LLC  
12630 U.S. 33 North, Churubusco, IN 46723  
Phone: (260)693-1972 Fax: (260)693-0602